



ETA-Danmark A/S
Göteborg Plads 1
DK-2150 Nordhavn
Tel. +45 72 24 59 00
Fax +45 72 24 59 04
Internet www.etadanmark.dk

Authorised and notified according
to Article 29 of the Regulation (EU)
No 305/2011 of the European
Parliament and of the Council of 9
March 2011

MEMBER OF EOTA



European Technical Assessment ETA-14/0105 of 2022/09/14

I General Part

Technical Assessment Body issuing the ETA and designated according to Article 29 of the Regulation (EU) No 305/2011: ETA-Danmark A/S

Trade name of the construction product:

BB Purlin Ties and Wind Brace Tighteners

Product family to which the above construction product belongs:

Three-dimensional nailing plate (Purlin Tie and wind brace tightener for timber to timber connections)

Manufacturer:

BB Stanz- und Umformtechnik GmbH
Nordhäuser Str. 44
D-06536 Berga
Tel. +49 34651 2988 0
Fax +49 34651 2988 20
Internet www.bb-berga.de

Manufacturing plant:

BB Stanz- und Umformtechnik GmbH
Nordhäuser Str. 44
D-06536 Berga

This European Technical Assessment contains:

20 pages including 2 annexes which form an integral part of the document

This European Technical Assessment is issued in accordance with Regulation (EU) No 305/2011, on the basis of:

European Assessment Document EAD 130186-00-0603

This version replaces:

The ETA with the same number issued on 2021-09-27

Translations of this European Technical Assessment in other languages shall fully correspond to the original issued document and should be identified as such.

Communication of this European Technical Assessment, including transmission by electronic means, shall be in full (excepted the confidential Annex(es) referred to above). However, partial reproduction may be made, with the written consent of the issuing Technical Assessment Body. Any partial reproduction has to be identified as such.

II SPECIFIC PART OF THE EUROPEAN TECHNICAL ASSESSMENT

1 Technical description of product

Technical description of the product

BB Purlin ties right/left 135, 170, 210, 250, 290, 330 and 370 and universal 170, 210, 250, 290, 330 and 370 are one-piece non-welded, face-fixed purlin ties to be used in timber to timber connections. They are connected to the timber elements by profiled nails.

The purlin ties are made from pre-galvanized steel S 250 GD + Z 275 according to EN 10346:2009.

BB Wind brace tighteners 30x55x2 and 40x60x2 are three-piece non-welded ties to be used in wind braces for timber structures. The braces are connected to the timber elements by profiled nails.

The wind brace tighteners are made using turnbuckles from steel S235JR according to EN 10025, pre-galvanized steel DD11 according to EN 10111 or with coating Fe/Zn/8B according to EN ISO 2081, studs 4.8 according to EN ISO 898-1 and nuts according to EN ISO 8673.

Dimensions, hole positions and typical installations are shown in Annex A. Purlin ties and wind brace tighteners are made from steel with tolerances according to EN 10143.

2 Specification of the intended use in accordance with the applicable European Assessment Document (hereinafter EAD)

The purlin ties or wind brace tighteners are intended for use in making connections in load bearing timber structures, as a connection between a beam and a purlin or two beams, where requirements for mechanical resistance and stability and safety in use in the sense of the Basic Works Requirements 1 and 4 of Regulation (EU) 305/2011 shall be fulfilled.

The connection always contains two purlin ties (see Annex A).

The static and kinematic behaviour of the timber members or the supports shall be as described in Annex B.

The wood members may be of solid timber, glued laminated timber and similar glued members, or wood-based structural members with a characteristic density

from 290 kg/m³ to 420 kg/m³. This requirement to the material of the wood members can be fulfilled by using the following materials:

- Structural solid timber according to EN 14081,
- Glulam according to EN 14080,
- LVL according to EN 14374,
- Parallam PSL,
- Intrallam LSL,
- Cross laminated timber according to EN 16351 or ETA,
- Plywood according to EN 636

Annex B states the load-carrying capacities of the purlin tie connections for a characteristic density of 350 kg/m³. For timber or wood based material with a different characteristic density than 350 kg/m³ the load-carrying capacities of the nailed connection shall be modified by the k_{dens} factor:

$$k_{\text{dens}} = \sqrt{\frac{\rho_k}{350}}$$

Where ρ_k is the characteristic density of the timber in kg/m³.

The design of the connections shall be in accordance with Eurocode 5 or a similar national Timber Code. The wood members shall have a thickness which is larger than the penetration depth of the nails into the members.

The purlin ties and wind brace tighteners made of pre-galvanized steel are primarily for use in timber structures subject to the dry, internal conditions defined by service class 1 and 2 of Eurocode 5 and for connections subject to static or quasi-static loading.

The scope of the purlin ties and wind brace tighteners regarding resistance to corrosion shall be defined according to national provisions that apply at the installation site considering environmental conditions.

The provisions made in this European Technical Assessment are based on an assumed intended working life of the purlin ties of 50 years.

The indications given on the working life cannot be interpreted as a guarantee given by the producer or Assessment Body, but are to be regarded only as a means for choosing the right products in relation to the expected economically reasonable working life of the works.

3 Performance of the product and references to the methods used for its assessment

Characteristic	Assessment of characteristic
3.1 Mechanical resistance and stability*) (BWR1)	
Joint Strength - Characteristic load-carrying capacity	See Annex B
Joint Stiffness	See Annex B
Joint ductility	No performance assessed
Resistance to seismic actions	No performance assessed
Resistance to corrosion and deterioration	See section 3.6
3.2 Safety in case of fire (BWR2)	
Reaction to fire	The purlin ties are made from steel classified as Euroclass A1 in accordance with EN 13501-1 and Commission Delegated Regulation 2016/364
3.3 General aspects related to the performance of the product	The purlin ties have been assessed as having satisfactory durability and serviceability when used in timber structures using the timber species described in Eurocode 5 and subject to the conditions defined by service class 1 and 2
Identification	See Annex A

*) See additional information in section 3.4 – 3.7.

3.4 Methods of verification

Safety principles and partial factors

The characteristic load-carrying capacities are based on the characteristic values of the nail connections, the timber components and the steel plates. To obtain design values the capacities have to be multiplied with different partial factors for the material properties, the nailed connection and the timber components in addition with the coefficient k_{mod} .

According to EN 1990 (Eurocode – Basis of design) paragraph 6.3.5 the design value of load-carrying capacity can be determined by reducing the characteristic values of the load-carrying capacity with different partial factors.

Thus, the characteristic values of the load-carrying capacity are determined also for timber failure $F_{Rk,H}$ (reaching the embedment strength of nails subjected to shear), $F_{90,Rk}$ (reaching the transverse tensile strength of the timber components) as well as for steel plate failure $F_{Rk,S}$. The design value of the load-carrying capacity is the smaller value of both load-carrying capacities.

$$F_{Rd} = \min \left\{ \frac{k_{mod} \cdot F_{Rk,N}}{\gamma_{M,H}}, \frac{F_{Rk,S}}{\gamma_{M,S}}, \frac{k_{mod} \cdot F_{90,Rk}}{\gamma_{M,H}} \right\}$$

Therefore, for timber failure and the nailed connection the load duration class and the service class are included. The different partial factors γ_M for steel or timber, respectively, are also correctly taken into account.

3.5 Mechanical resistance and stability

See annex B for the characteristic load-carrying capacity in the direction F_1 .

The characteristic capacities of the purlin ties and wind brace tighteners are determined by calculation assisted by testing as described in EAD 130186-00-0603 section 2.2.1.1. They should be used for designs in accordance with Eurocode 5 or a similar national Timber Code.

Threaded nails (ringed shank nails) in accordance to EN 14592

In the formulas in Annex B the capacities for threaded nails calculated from the formulas of Eurocode 5 are used assuming a thick steel plate when calculating the lateral nail load-carrying-capacity.

The load bearing capacities of the brackets has been determined based on the use of connector nails 4,0 x 40 mm in accordance with the German national approval for the nails.

The characteristic withdrawal capacity of the nails has to be determined by calculation in accordance with EN 1995-1-1: 2004, paragraph 8.3.2 (head pull-through is not relevant):

$$F_{ax,Rk} = f_{ax,k} \times d \times t_{pen}$$

Where:

$f_{ax,k}$	Characteristic value of the withdrawal parameter in N/mm ²
d	Nail diameter in mm
t_{pen}	Penetration depth of the profiles shank in mm, $t_{pen} \geq 30$ mm

Based on tests by Versuchsanstalt für Stahl, Holz und Steine, University of Karlsruhe, the characteristic value of the withdrawal resistance for the threaded nails used can be calculated as:

$$f_{ax,k} = 6,125 \text{ N/mm}^2$$

The shape of the nail directly under the head shall be in the form of a truncated cone with a diameter under the nail head which exceeds the hole diameter.

4,0 mm threaded nails with a truncated cone below the head are used as fasteners, which are particularly suitable for nailed steel-to-timber connections. The specific shape below the head causes a clamping of nails in the steel plate.

Screws in accordance to EN 14592

The load-carrying-capacities of the purlin ties have been determined based on the use of connector nails 4,0 x 40 mm. The nails may be replaced by screws according to EN 14592 with following characteristics:

$$f_{ax,k} = 12,0 \text{ N/mm}^2 ; M_{y,k} = 5900 \text{ Nmm} ; l_{ef} = 35,0 \text{ mm} ; d_1 = 3,0 \text{ mm}$$

Where:

$f_{ax,k}$	Characteristic value of the withdrawal parameter in N/mm ²
$M_{y,k}$	Characteristic value of the yield moment in Nmm
l_{ef}	Length of the threaded part of the screw in mm
d_1	Root diameter of the threaded part of the screw in mm

The shape of the screw directly under the head shall be in the form of a truncated cone with a diameter under the screw head which exceeds the hole diameter.

5,0 mm screws with a truncated cone below the head are used as fasteners, which are particularly suitable for screwed steel-to-timber connections. The specific shape below the head causes a clamping of screws in the steel plate.

No performance has been determined in relation to ductility of a joint under cyclic testing. The contribution to the performance of structures in seismic zones, therefore, has not been assessed.

No performance has been determined in relation to the joint's stiffness properties - to be used for the analysis of the serviceability limit state.

3.6 Aspects related to the performance of the product

3.6.1 Corrosion protection in service class 1 and 2.

The purlin ties and wind brace tighteners have a zinc coating weight of min Z27510111 or with 8 µm coating Fe/Zn/8B according to EN ISO 2081. The steel employed is DD11 according to EN 10111 or S250 GD with min Z275 according to EN 10346:2009. In service class 2 the nails must also have a zinc coating according to table 4.1 of Eurocode 5 (zinc coating Fe/Zn 12c according to EN ISO 2081 or Z275 according to EN 10147).

3.7 General aspects related to the fitness for use of the product

The purlin ties are manufactured in accordance with the provisions of this European Technical Assessment using the manufacturing processes as identified in the inspection of the plant by the notified inspection body and laid down in the technical documentation

The following provisions concerning product performance apply:

- The structural members to which the purlin ties are fixed shall be:
 - Restrained against rotation.
 - Solid timber according to EN 338 or better, see section II.2
 - Free from wane under the purlin tie.
- The tensile perpendicular to the grain capacity of the timber member to be used in conjunction with the purlin tie is to be checked by the designer of the structure to ensure it is not less than the purlin tie capacity and, if necessary, the purlin tie capacity reduced accordingly.
- The fastener pattern used shall be as defined in Annex B. The minimum number of nails per Purlin Tie is given in table B.1. The holes have to be nailed beginning at the end of the purlin tie.
- Minimum distances to the edges of the timber member according to EN 1995-1-1 have to be considered
- The gap between the timber members does not exceed 3 mm.
- There are no specific requirements relating to preparation of the timber members.

4 Attestation and verification of constancy of performance (AVCP)

4.1 AVCP system

According to the decision 97/638/EC of the European Commission, as amended, the system(s) of assessment and verification of constancy of performance (see Annex V to Regulation (EU) No 305/2011) is 2+.

5 Technical details necessary for the implementation of the AVCP system, as foreseen in the applicable EAD

Technical details necessary for the implementation of the AVCP system are laid down in the control plan deposited at ETA-Danmark prior to CE marking

Issued in Copenhagen on 2022-09-14 by



Thomas Bruun
Managing Director, ETA-Danmark

Annex A
Product details

Product details definitions

Table A.1 Materials specification

Purlin Ties Type		Thickness (mm)	Steel specification	Coating specification
right/left (135-370)		2,0	S 250 GD + Z 275	Z 275
universal (170-370)		2,0	S 250 GD + Z 275	Z 275
Wind brace tightener Type	Component of wind brace tightener	Thickness or diameter (mm)	Steel specification	Coating specification
30x65x2	Turnbuckle	M10	S235JR	Fe/Zn 12c or Fe/Zn/8B
	Steel plates	2,0	DD11	Fe/Zn 12c or Fe/Zn/8B
	Stud	M10	4.8	Fe/Zn 12c or Fe/Zn/8B
	Nut	M10	4.8	Fe/Zn 12c or Fe/Zn/8B
40x70x2	Turnbuckle	M16	S235JR	Fe/Zn 12c or Fe/Zn/8B
	Steel plates	2,0	DD11	Fe/Zn 12c or Fe/Zn/8B
	Stud	M16	4.8	Fe/Zn 12c or Fe/Zn/8B
	Nut	M16	4.8	Fe/Zn 12c or Fe/Zn/8B

Table A.2 Dimensions

Purlin Ties Type	Length (mm)		Width (mm)	
	min	max	min	max
right/left 135	134	137	33	34
right/left 170	169	172	34	35
right/left 210	209	212	34,5	35,5
right/left 250	249	252	35,5	36,5
right/left 290	289	292	35,5	36,5
right/left 330	329	332	35,5	36,5
right/left 370	369	372	35,5	36,5
universal 170	169	172	34,5	35,5
universal 210	209	212	34,5	35,5
universal 250	249	252	34,5	35,5
universal 290	289	292	34,5	35,5
universal 330	329	332	34,5	35,5
universal 370	369	372	34,5	35,5

Table A.3 Fastener specification

Fastener type	Nail size (mm)		Finish
	Diameter	Length	
According to EN 14592	4,0	40	Electroplated zinc
Threaded nail			
<p>In the load-carrying-capacities of the nailed connection in Annex B the capacities for threaded nails calculated from the formulas of Eurocode 5 are used assuming a thick steel plate when calculating the lateral nail load-carrying-capacity.</p> <p>The load-carrying-capacities of the purlin ties have been determined based on the use of connector nails 4,0 x 40 mm in accordance with the German national approval for the nails.</p> <p>The characteristic withdrawal capacity of the nails has to be determined by calculation in accordance with EN 1995-1-1:2004, paragraph 8.3.2 (head pull-through is not relevant):</p> $F_{ax,Rk} = f_{ax,k} \times d \times t_{pen}$ <p>Where:</p> <p>$f_{ax,k}$ Characteristic value of the withdrawal parameter in N/mm²</p> <p>d Nail diameter in mm</p> <p>t_{pen} Penetration depth of the profiled shank including the nail point in mm, $t_{pen} \geq 30$ mm</p> <p>Based on tests by Versuchsanstalt für Stahl, Holz und Steine, Karlsruhe Institute of Technology, the characteristic value of the withdrawal resistance for the threaded nails used in timber with a characteristic density can be assumed as:</p> $f_{ax,k} = 6,125 \text{ N/mm}^2$ <p>The shape of the nail directly under the head shall be in the form of a truncated cone with a diameter under the nail head which exceeds the hole diameter.</p>			

Fastener type	Screw size (mm)		Finish
	Diameter	Length	
According to EN 14592	5,0	40	Electroplated zinc
Screw			
<p>The load-carrying-capacities of the purlin ties have been determined based on the use of connector nails 4,0 x 40 mm. The nails may be replaced by screws according to EN 14592 with following characteristics:</p> $f_{ax,k} = 12,0 \text{ N/mm}^2 ; M_{y,k} = 5900 \text{ Nmm} ; l_{ef} = 35,0 \text{ mm} ; d_1 = 3,0 \text{ mm}$ <p>Where:</p> <p>$f_{ax,k}$ Characteristic value of the withdrawal parameter in N/mm²</p> <p>$M_{y,k}$ Characteristic value of the yield moment in Nmm</p> <p>l_{ef} Length of the threaded part of the screw in mm</p> <p>d_1 Root diameter of the threaded part of the screw in mm</p> <p>The shape of the screw directly under the head shall be in the form of a truncated cone with a diameter under the screw head which exceeds the hole diameter</p>			

Fastener type	Bolt size (mm)		Finish
	Diameter	Length	
According to ISO 4017	4,0	20	Electroplated zinc
Bolt			

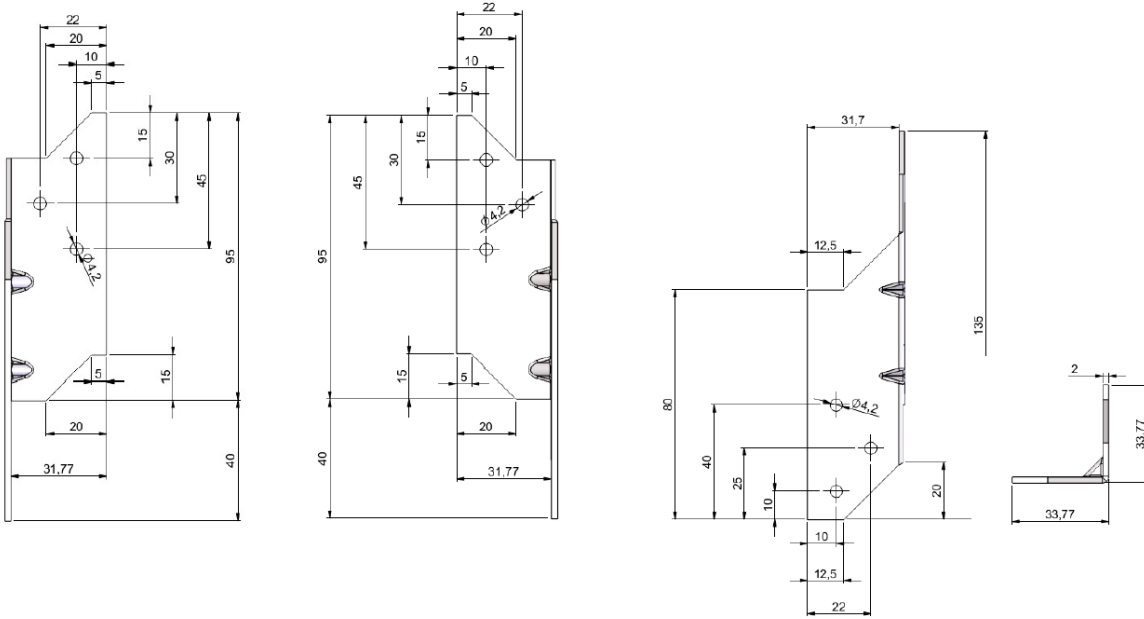

Figure A. 1 Dimensions of Purlin ties 135 right/left

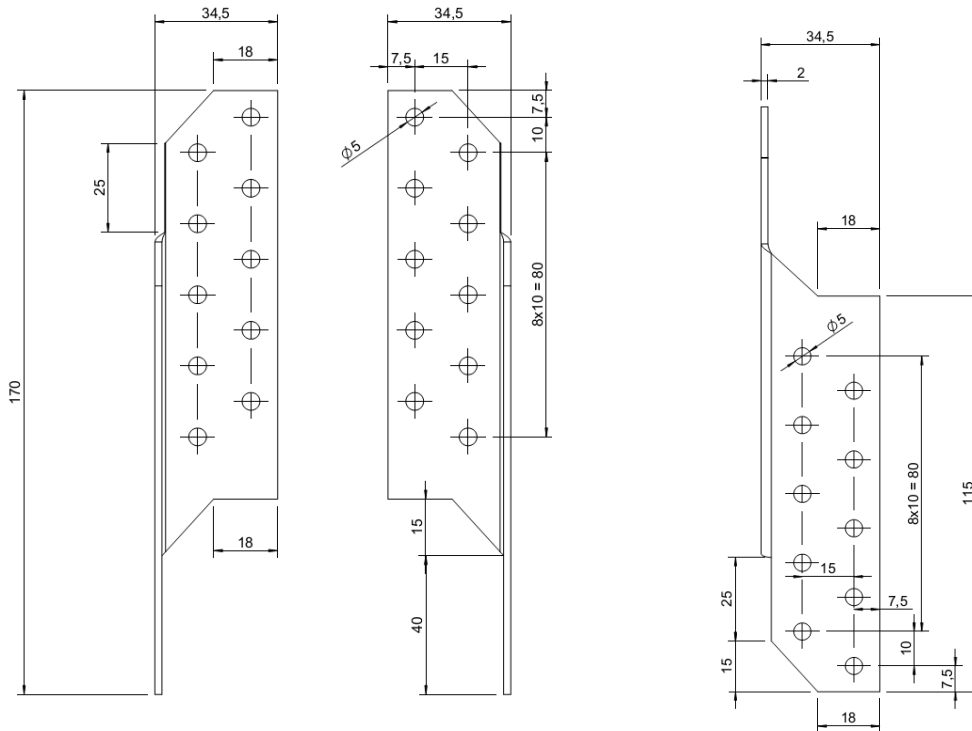

Figure A. 2 Dimensions of Purlin ties 170 right/left

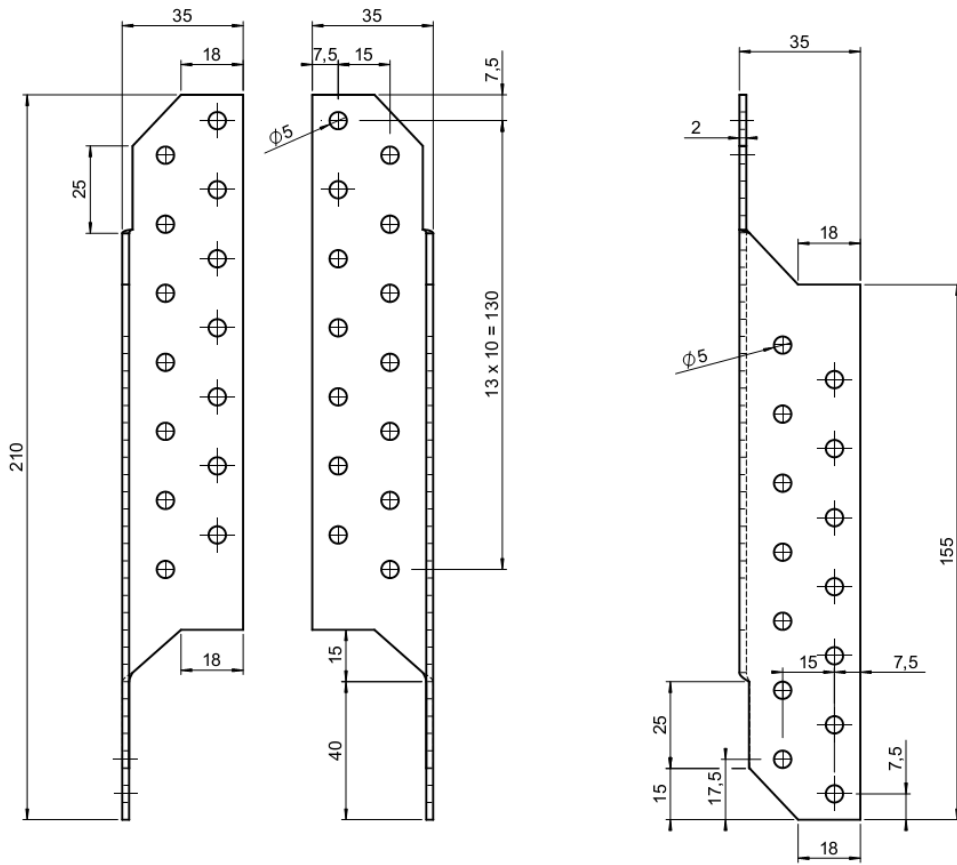

Figure A. 3 Dimensions of Purlin ties 210 right/left

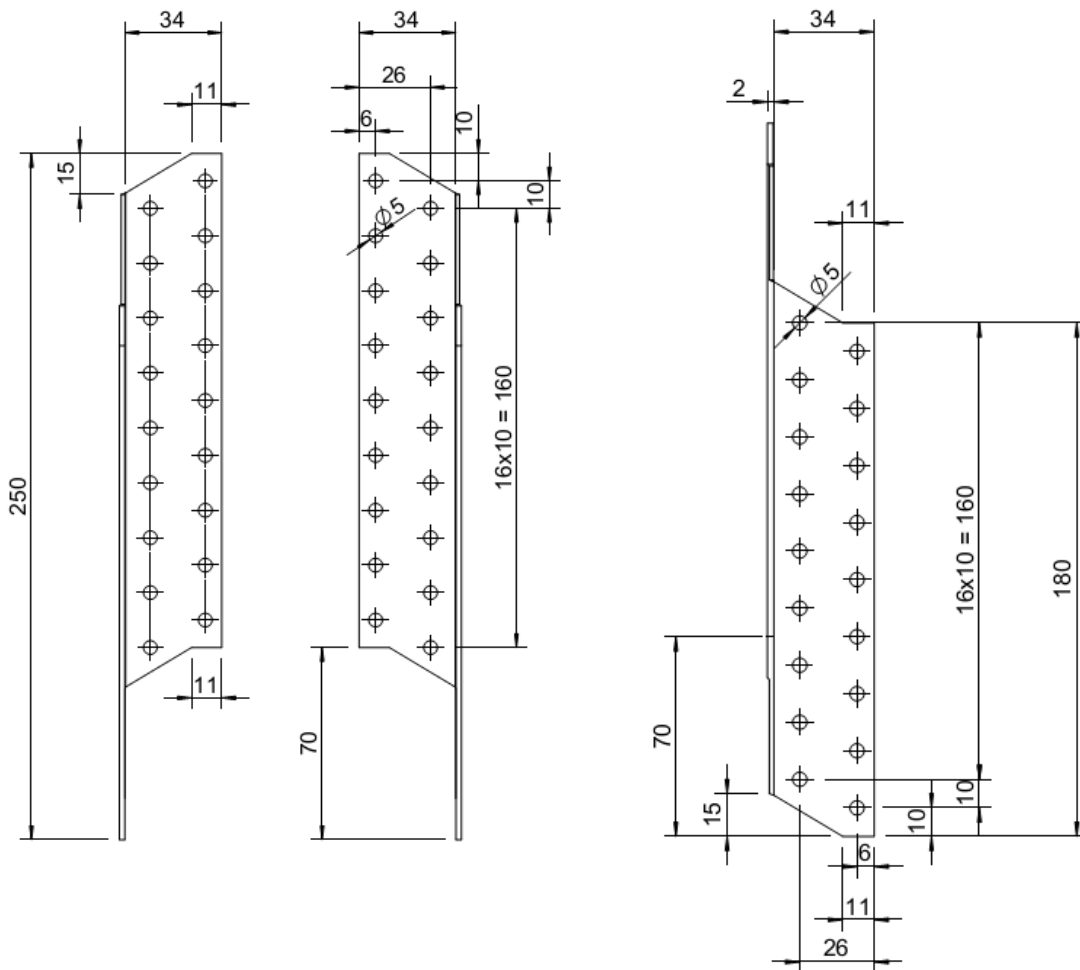

Figure A. 4 Dimensions of Purlin ties 250 right/left

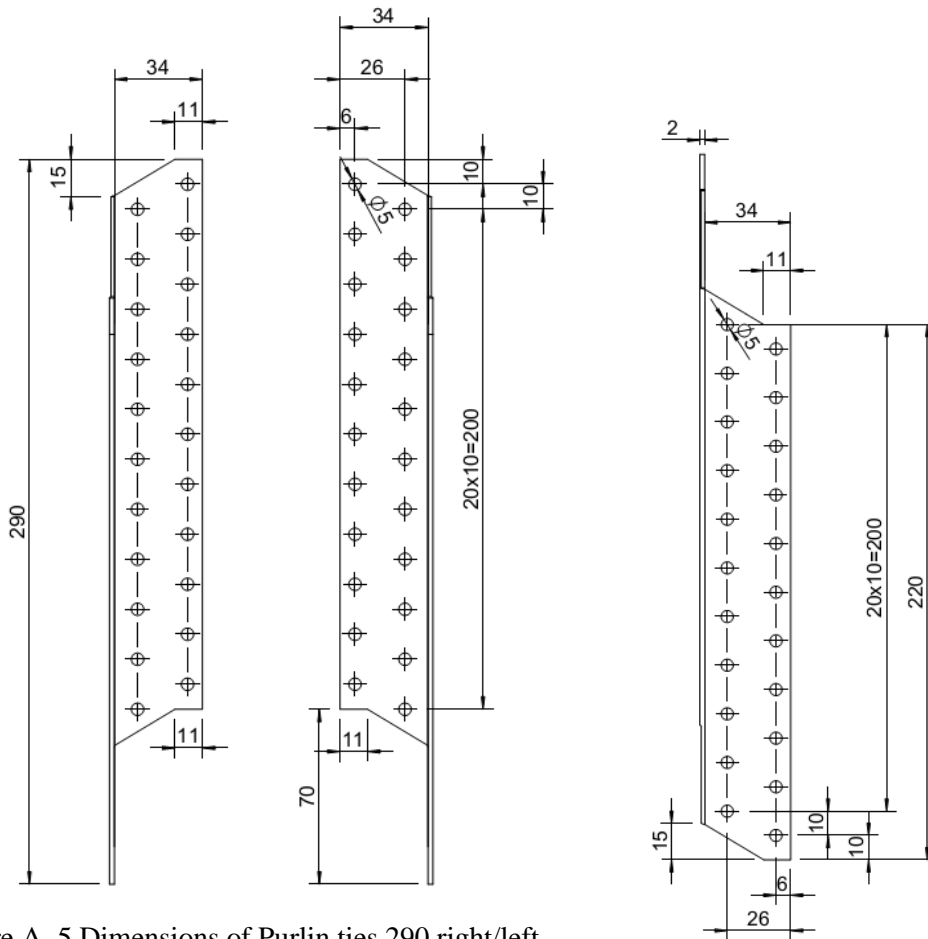

Figure A. 5 Dimensions of Purlin ties 290 right/left

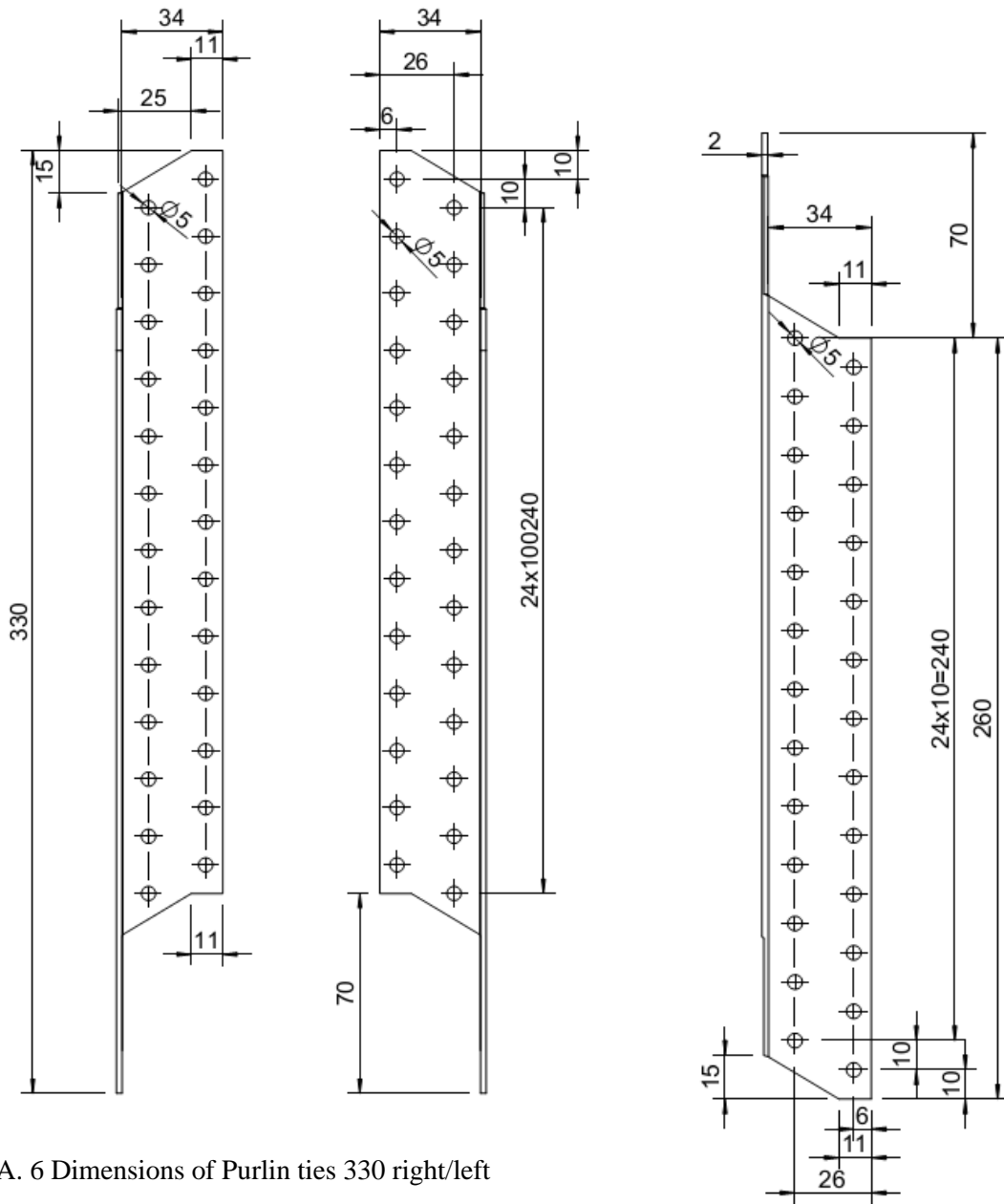

Figure A. 6 Dimensions of Purlin ties 330 right/left

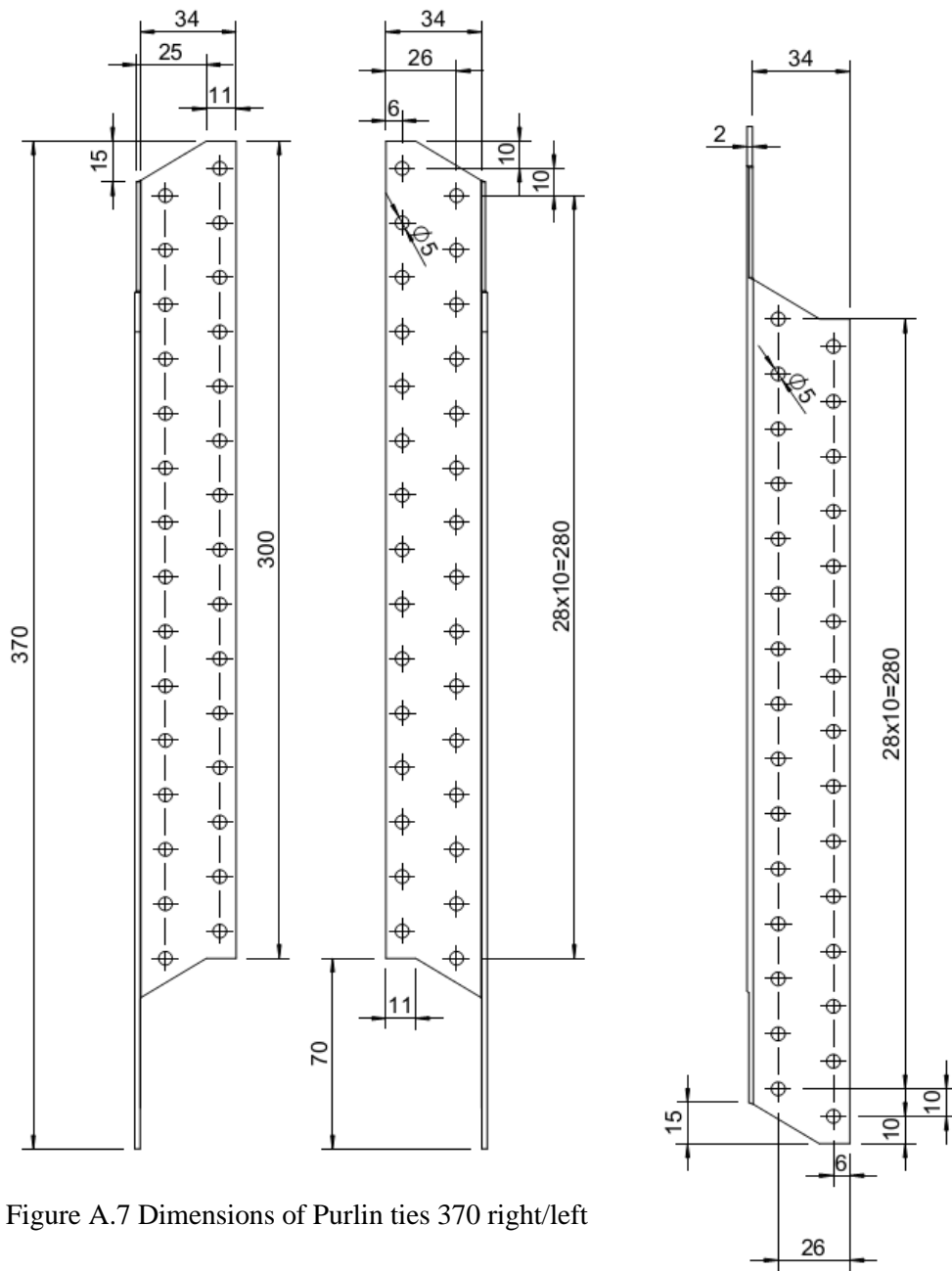

Figure A.7 Dimensions of Purlin ties 370 right/left

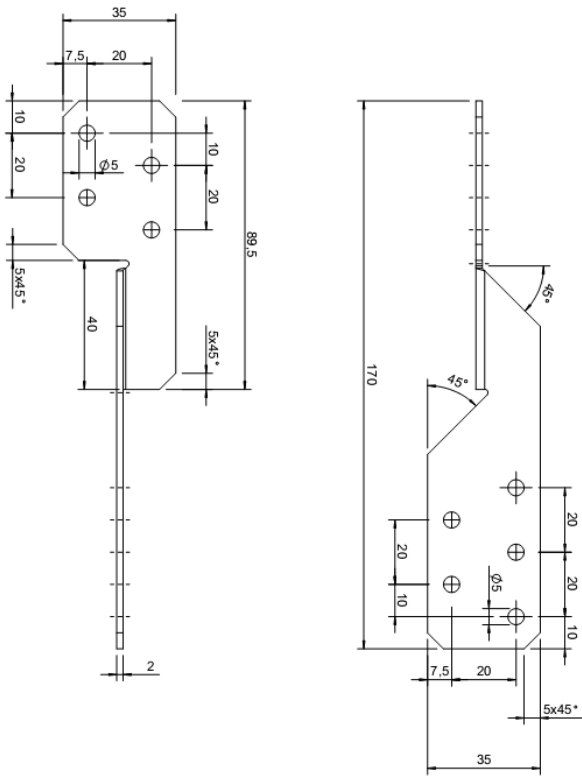

Figure A.8 Dimensions of Purlin ties 170 universal

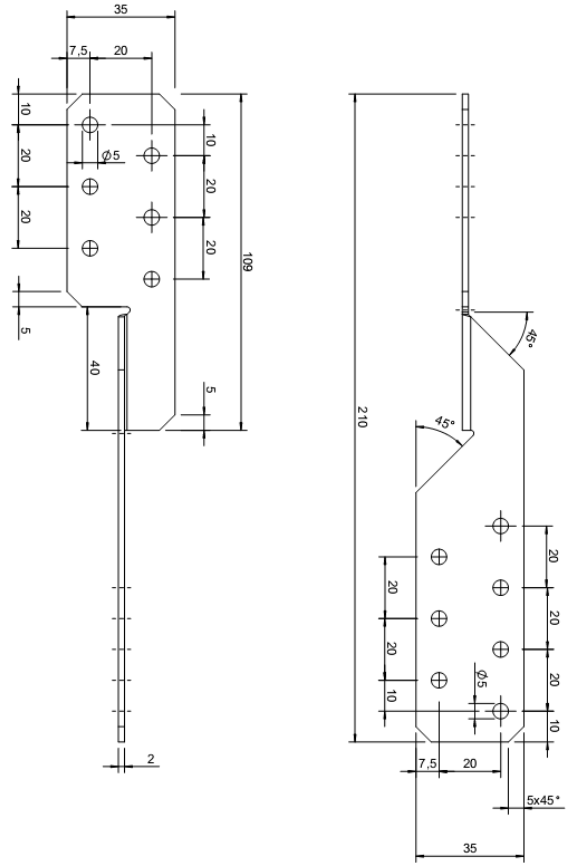

Figure A.9 Dimensions of Purlin ties 210 universal

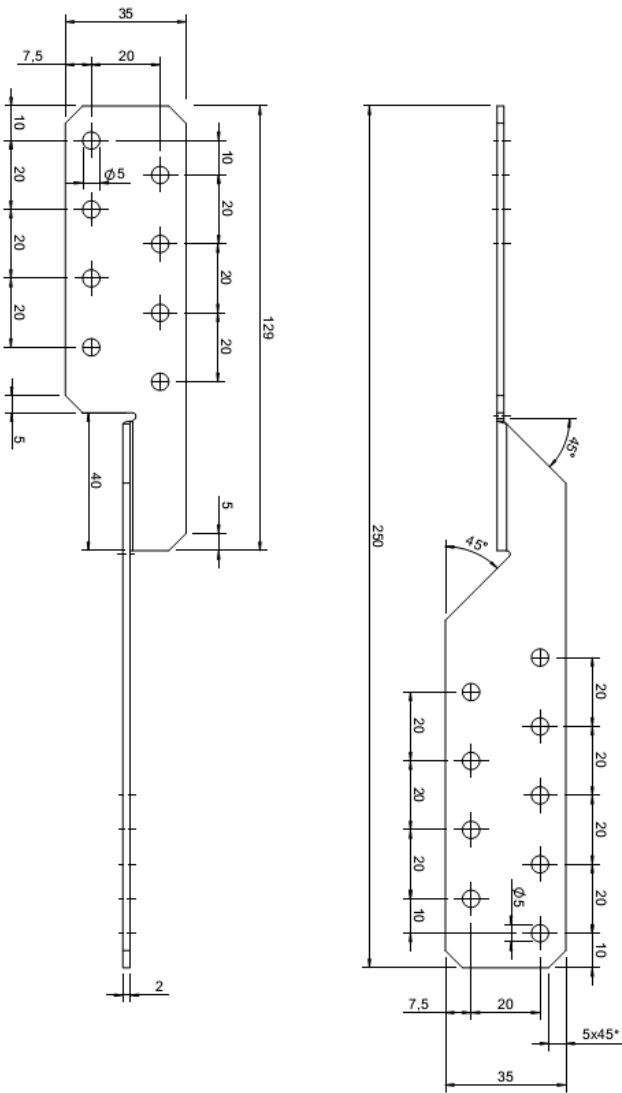

Figure A.10 Dimensions of Purlin ties 250 universal

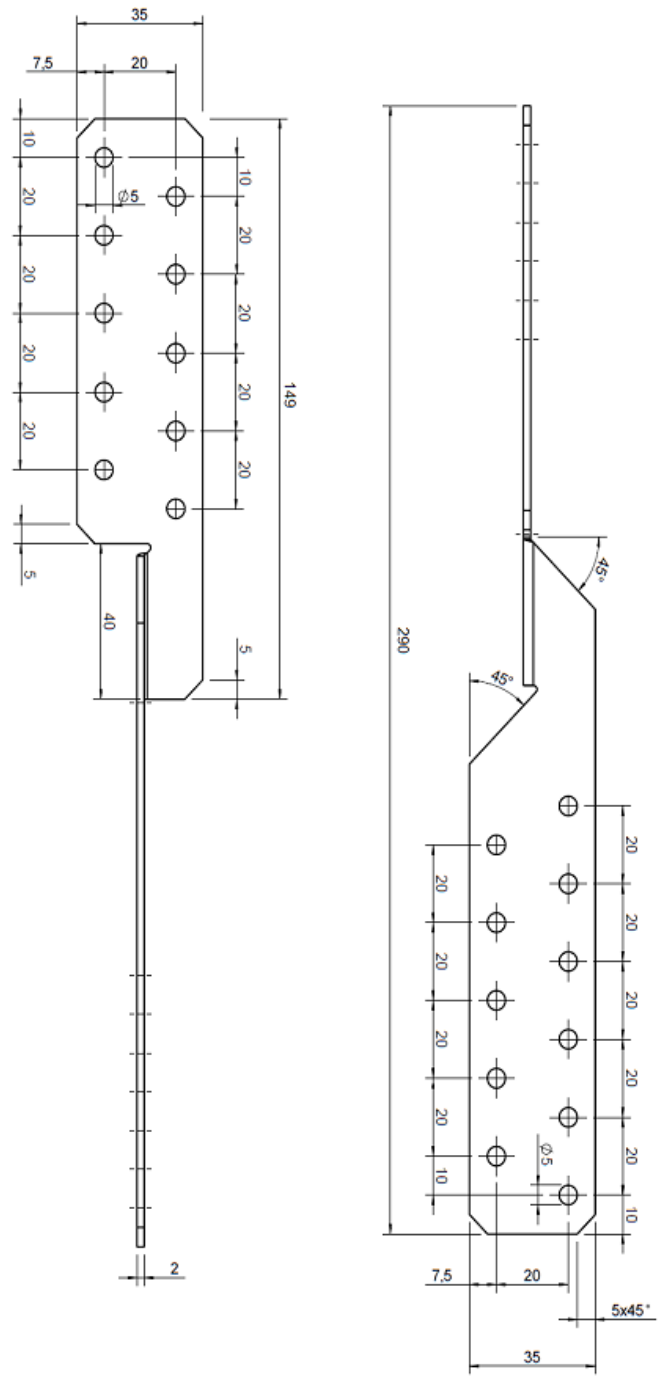

Figure A.11 Dimensions of Purlin ties 290 universal

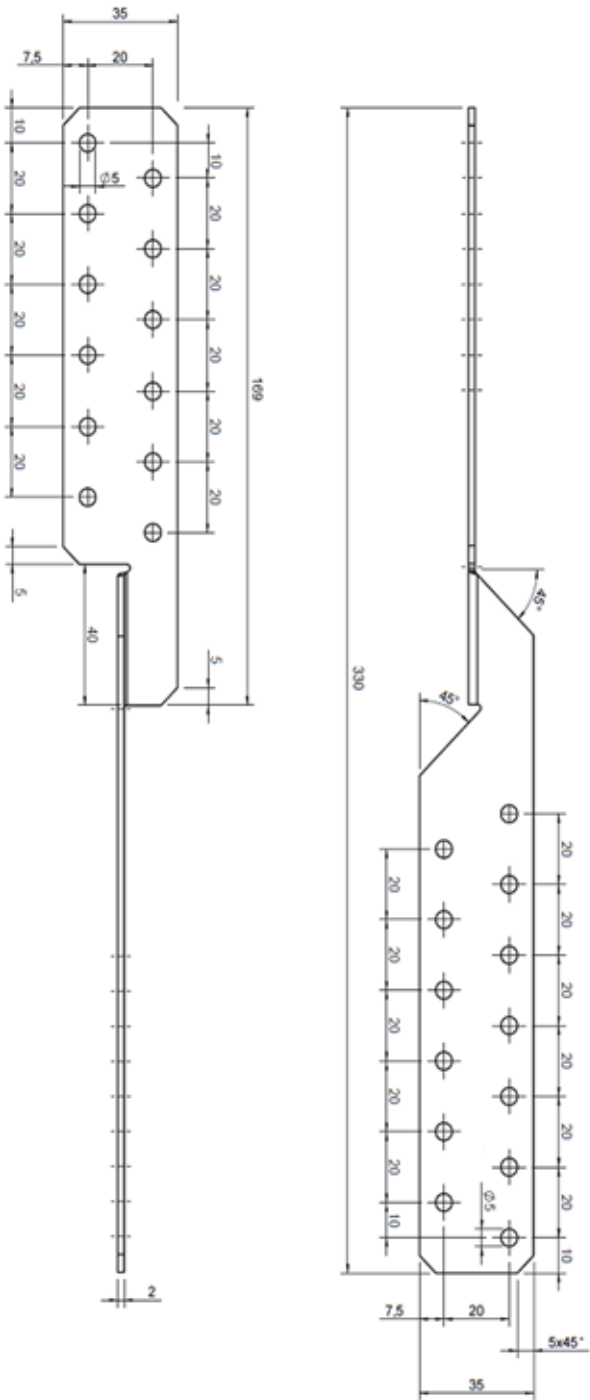

Figure A.12 Dimensions of Purlin ties 330 universal

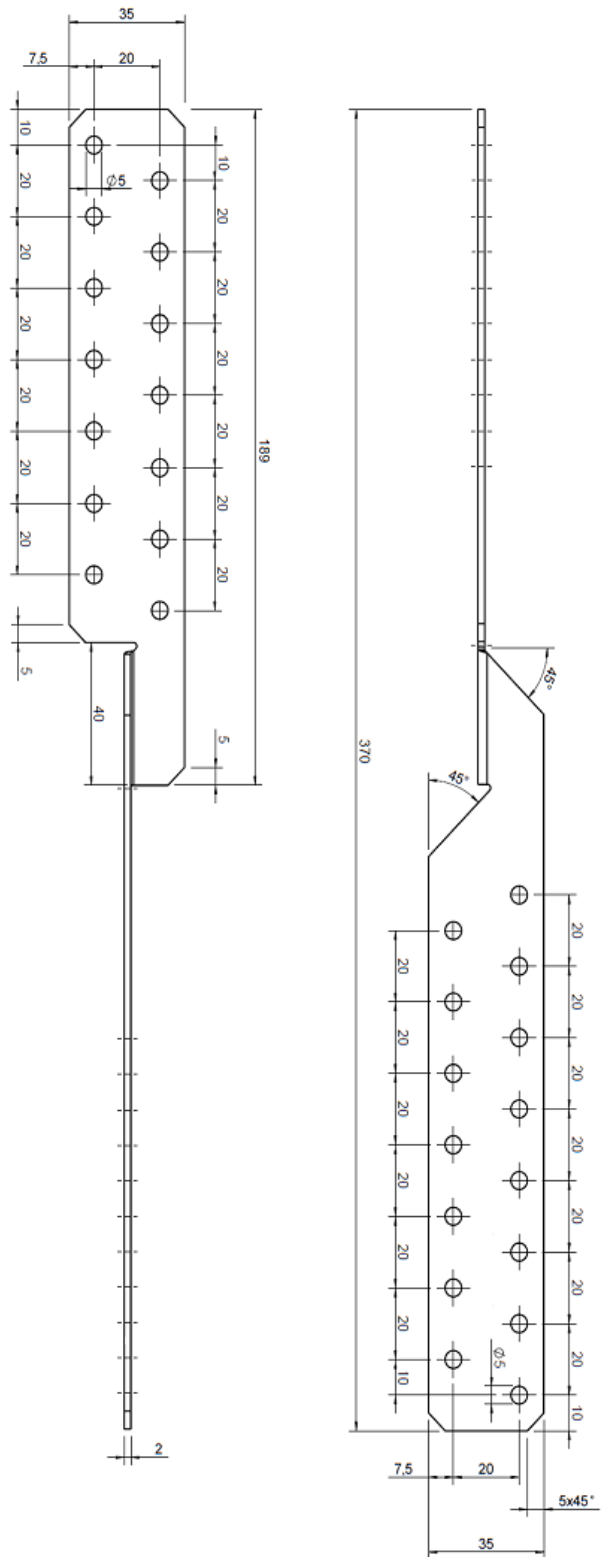

Figure A.13 Dimensions of Purlin ties 370 universal

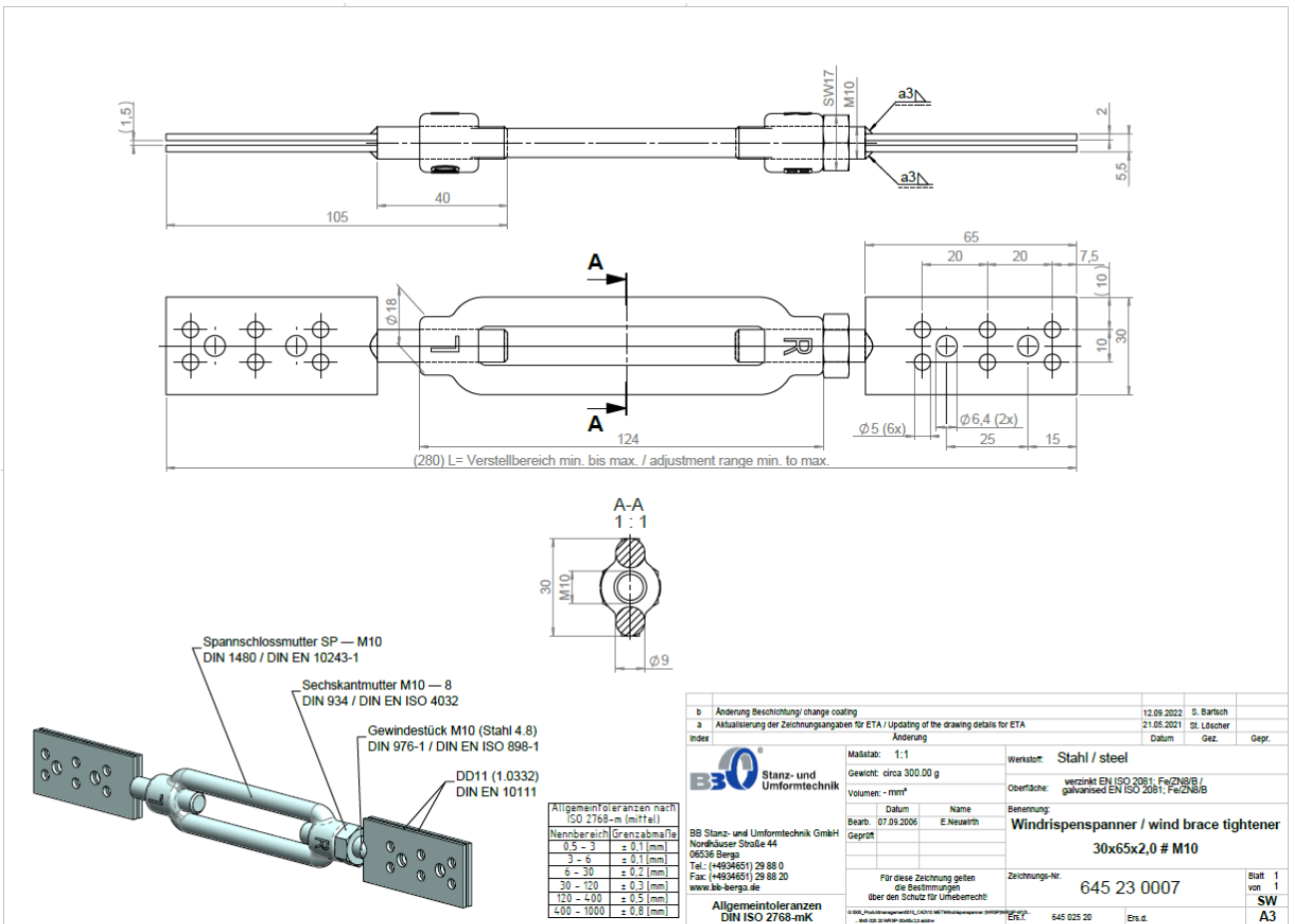

Figure A. 14 Wind brace tightener 30x65x2

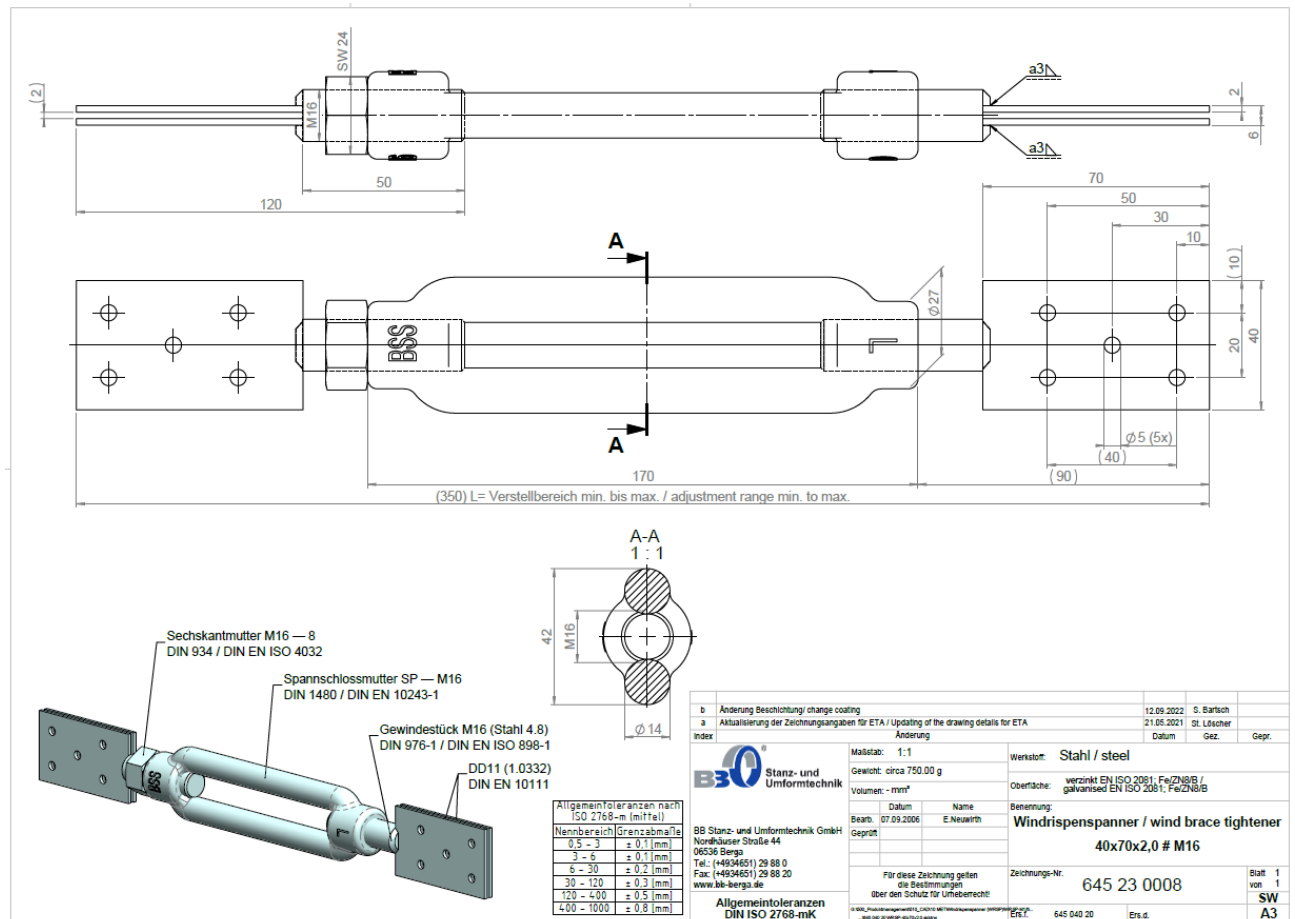

Figure A. 15 Wind brace tightener 40x70x2

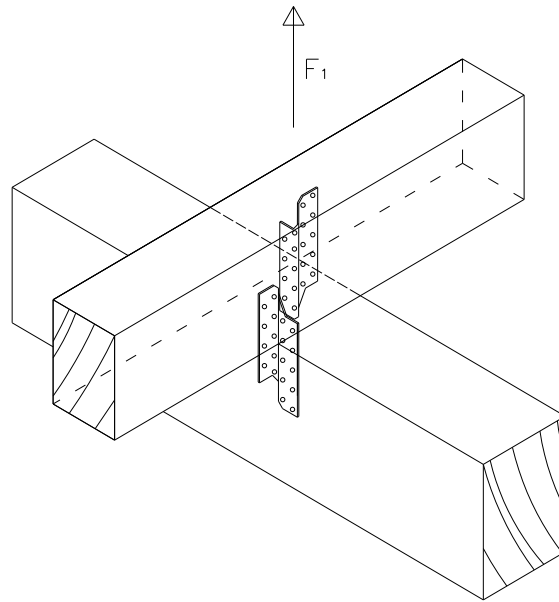

Figure A. 16 Typical installation

Annex B

Characteristic load-carrying capacities

Support conditions

The distance between the timber elements in the area of the connection must not exceed 3 mm. The timber members are prevented from rotation.

Fastener specification

The holes have to be nailed as given in Annex A, beginning at the end of the purlin tie.

Wane

Wane is not allowed, the timber has to be sharp-edged in the area of the purlin ties.

Characteristic load-carrying capacities 2 purlin ties

Table B.1: Characteristic load-carrying capacities Load F_1 – 2 Purlin Ties / connection in kN

Purlin Ties	Number of nails per Purlin Tie	Nailed connection $F_{Rk,N}$	Steel $F_{Rk,S}$	Transverse tensile failure
right/left 135	2 x 2	2,49	10,4	Design according to equation (B.1)
right/left 170	2 x 4	5,33	10,4	
right/left 210	2 x 6	9,56	10,4	
right/left 250	2 x 8	14,9	10,4	
right/left 290	2 x 10	20,7	10,4	
right/left 330	2 x 12	27,0	10,4	
right/left 370	2 x 14	35,6	10,4	
universal 170	4 + 5	12,3	6,62	
universal 210	6 + 7	18,9	6,62	
universal 250	8 + 9	25,4	6,62	
universal 290	10 + 11	31,8	6,62	
universal 330	12 + 13	38,3	6,62	
universal 370	14 + 15	44,9	6,62	

Characteristic load-carrying capacity of one wind brace tightener

Table B.2: Characteristic load-carrying capacities Load F_1 – 1 Wind brace tightener / connection in kN

Wind brace tightener	Number of bolts per Wind brace tightener	Steel $F_{Rk,S}$
30x65x2	2 x 3	8,7
40x70x2	2 x 4	13,9

Splitting

For a lifting force F_1 splitting has to be proved, when necessary, for both timber elements. The capacity of a connection with two purlin ties on both sides of the timber element is calculated according to the general splitting design for connections with mechanical fasteners in EN 1995:2010.

$$F_{90,Rk} = 14 \cdot b \sqrt{\frac{h_e}{\left(1 - \frac{h_e}{h}\right)}} \quad (B.1)$$

Where:

- $F_{90,Rk}$ the characteristic splitting capacity in N
- b the member thickness, in mm
- h_e is the loaded edge distance to the centre of the most distant fastener in mm
- h the timber member height in mm

The design value of the force component perpendicular to the structural member's axis has to be lower than the design capacity $F_{90,Rd}$.