

Approval body for construction products
and types of construction

Bautechnisches Prüfamt

An institution established by the Federal and
Laender Governments



European Technical Assessment

ETA-05/0267
of 11 August 2020

English translation prepared by DIBt - Original version in German language

General Part

Technical Assessment Body issuing the
European Technical Assessment:

Deutsches Institut für Bautechnik

Trade name of the construction product

alfa Iso-Universalanchor IUD

Product family
to which the construction product belongs

Nailed-in plastic anchor for fixing of external thermal
insulation composite systems with rendering in concrete
and masonry

Manufacturer

alfa Dübel GmbH
Braukämperstraße 101
45899 Gelsenkirchen

Manufacturing plant

alfa Dübel GmbH

This European Technical Assessment
contains

12 pages including 3 annexes which form an integral part
of this assessment

This European Technical Assessment is
issued in accordance with Regulation (EU)
No 305/2011, on the basis of

EAD 330196-01-0604, Edition 10/2017

This version replaces

ETA-05/0267 issued on 19 January 2016

The European Technical Assessment is issued by the Technical Assessment Body in its official language. Translations of this European Technical Assessment in other languages shall fully correspond to the original issued document and shall be identified as such.

Communication of this European Technical Assessment, including transmission by electronic means, shall be in full. However, partial reproduction may only be made with the written consent of the issuing Technical Assessment Body. Any partial reproduction shall be identified as such.

This European Technical Assessment may be withdrawn by the issuing Technical Assessment Body, in particular pursuant to information by the Commission in accordance with Article 25(3) of Regulation (EU) No 305/2011.

Specific Part

1 Technical description of the product

The allfa Iso-Universalanchor IUD with a plate consists of a plastic part made of polyethylene (virgin material) and an accompanying specific nail of galvanised steel with an integrally moulded plastic head made of polyamide.

The anchor may in addition be combined with the anchor plates IUS 140, IUS 110 or IUS 90 made of polyethylene.

The description of the product is given in Annex A.

2 Specification of the intended use in accordance with the applicable European Assessment Document

The performances given in Section 3 are only valid if the anchor is used in compliance with the specifications and conditions given in Annex B.

The verification and assessment methods on which this European Technical Assessment is based lead to the assumption of a working life of the anchor of at least 25 years. The indications given on the working life cannot be interpreted as a guarantee given by the producer, but are to be regarded only as a means for choosing the right products in relation to the expected economically reasonable working life of the works.

3 Performance of the product and references to the methods used for its assessment

3.1 Safety and accessibility in use (BWR 4)

Essential characteristic	Performance
Characteristic load bearing capacity - Characteristic resistance under tension load - Minimum edge distance and spacing	See Annex C 1 See Annex B 2
Displacements	See Annex C 2
Plate stiffness	See Annex C 2

3.2 Energy economy and heat retention (BWR 6)

Essential characteristic	Performance
Point thermal transmittance	See Annex C 2

4 Assessment and verification of constancy of performance (AVCP) system applied, with reference to its legal base

In accordance with EAD No. 330196-01-0604, the applicable European legal act is: [97/463/EC].

The system to be applied is: 2+

5 Technical details necessary for the implementation of the AVCP system, as provided for in the applicable EAD

Technical details necessary for the implementation of the AVCP system are laid down in the control plan deposited with Deutsches Institut für Bautechnik.

Issued in Berlin on 11 August 2020 by Deutsches Institut für Bautechnik

BD Dipl.-Ing. Andreas Kummerow
Head of Department

beglaubigt:
Ziegler

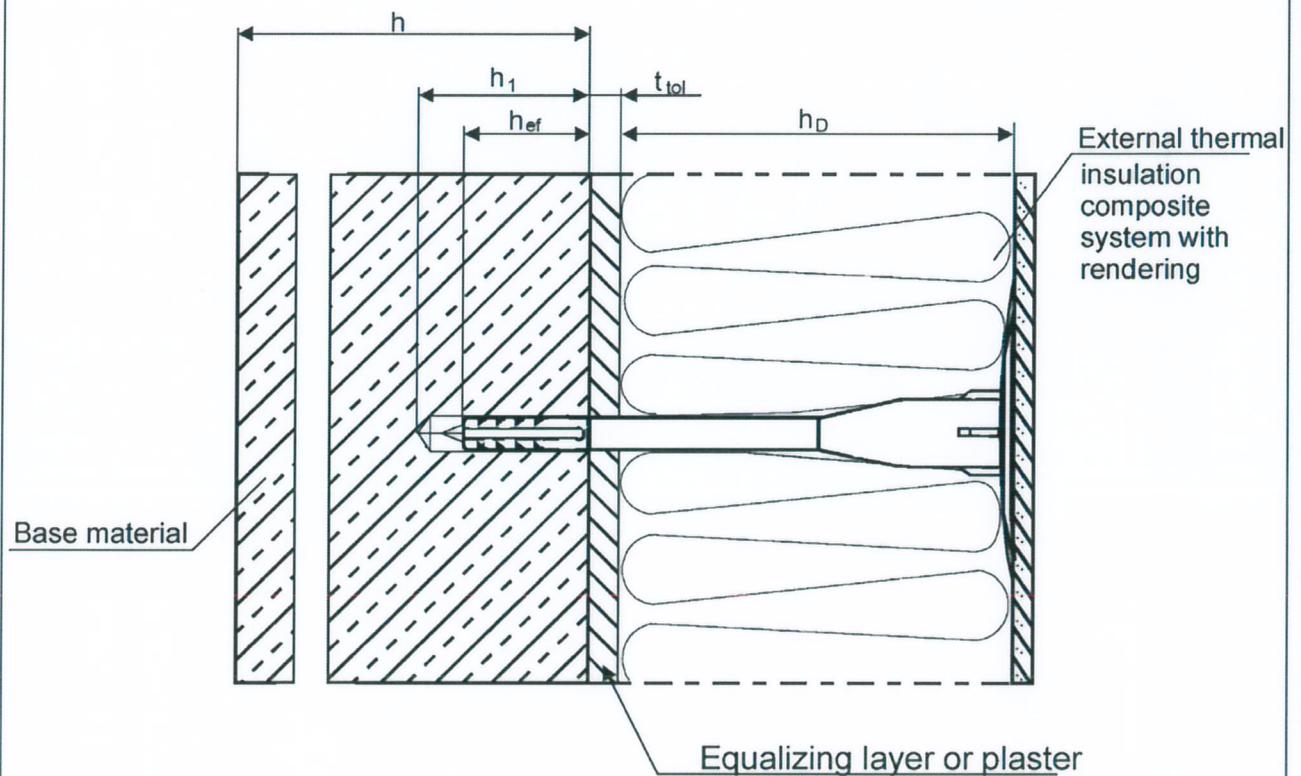

Intended use

- Fixing of external thermal insulation composite systems in concrete and masonry

Legend:

- h_D = thickness of insulation material
- h_{ef} = effective anchorage depth
- h = thickness of member (wall)
- h_1 = depth of drilled hole to deepest point
- t_{tol} = thickness of equalizing layer or non load bearing coating

allfa Iso-Universalanchor IUD

Product description
Installed condition

Annex A 1

<p>Nail with an integrally moulded plastic head</p>						
<p>Table 1: Dimensions</p>						
<p style="text-align: right;">Measures in mm</p>						
Anchor type	Anchor sleeve				Nail	
	d_{nom}	h_{ef}	$min L_a$	$max L_a$	d_s	c
alfa IUD	8	30	90	240	5,2	45
<p>Determination of maximum thickness of insulation material h_D z.B.: $h_D = L_a - t_{td} - h_{ef}$ ($L_a = z.B. 90; t_{td} = 10$) $h_D = 90 - 10 - 30$ $h_{Dmax} = 50$</p>						
<p>Table 2: Materials</p>						
Element	Material					
Anchor sleeve	virgin Polyethylene PE, colours: natural, white, grey, blue, orange, red, green					
Specific nail	Steel galvanized $\geq 5 \mu m$ according EN ISO 4042:2018					
Plastic head of the nail	Polyamide PA 6.0					
<p>alfa Iso-Universalanchor IUD</p>					<p>Annex A 2</p>	
<p>Product description Dimensions, materials and marking of the anchor sleeve and specific nail</p>						

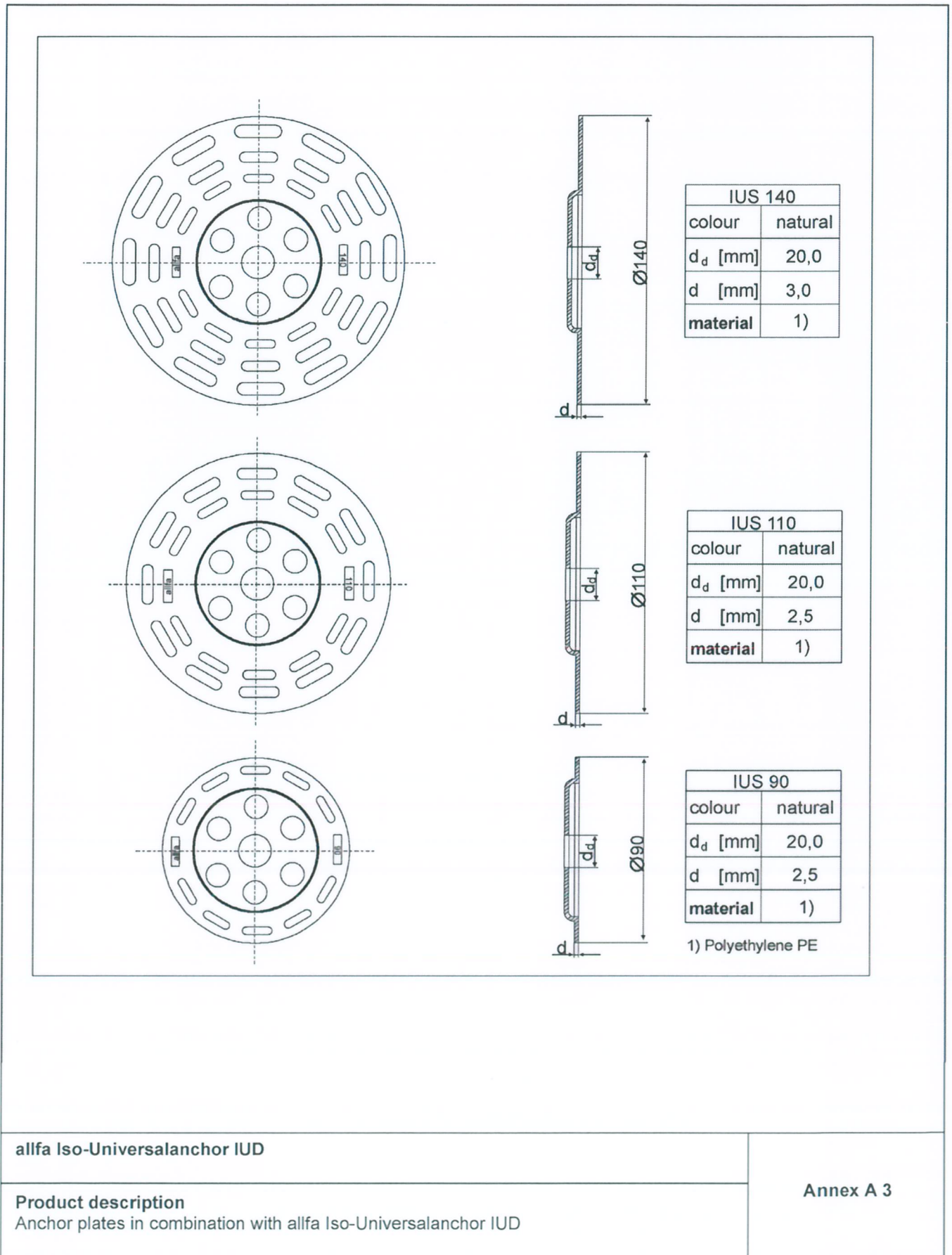

alfa Iso-Universalanchor IUD

Product description

Anchor plates in combination with alfa Iso-Universalanchor IUD

Annex A 3

Specifications of intended use

Anchorage subject to:

- The anchor may only be used for transmission of wind suction loads and shall not be used for the transmission of dead loads of the thermal insulation composite system.

Base materials:

- Normal weight concrete (base material group A) according to Annex C 1
- Solid masonry (base material group B), according to Annex C 1
- Hollow or perforated masonry (base material group C), according to Annex C 1
- For other base materials of the base material groups A, B or C the characteristic resistance of the anchor may be determined by job site tests according to EOTA Technical Report TR 51 edition December 2016.

Temperature Range:

- 0°C to +40°C (max. short term temperature +40°C and max. long term temperature +24°C)

Design:

- The anchorages are designed under the responsibility of an engineer experienced in accordance and masonry work with the partial safety factors $\gamma_m = 2,0$ and $\gamma_F = 1,5$ if there are no other regulations.
- Verifiable calculation notes and drawings are prepared taking account of the loads to be anchored. The position of the anchor is indicated on the design drawings.
- Fasteners are only to be used for multiple fixings of thermal insulation composite systems.

Installation:

- Hole drilling by the drill modes according to Annex C 1
- Anchor installation carried out by appropriately qualified personnel and under the supervision of the person responsible for technical matters of the site.
- Installation temperature from 0°C to +40°C
- Exposure to UV due to solar radiation of the anchor not protected by rendering ≤ 6 weeks

alfa Iso-Universalanchor IUD	Annex B 1
Intended use Specifications	

Table 3: Installation parameters

Anchor type		alfa IUD
Drill hole diameter	d_o [mm] =	8
Cutting diameter of drill bit	d_{cut} [mm] \leq	8,45
Depth of drilled hole to deepest point	h_1 [mm] \geq	40
Effective anchorage depth	h_{ef} [mm] \geq	30

Table 4: Anchor distances and dimensions of members

Anchor type		alfa IUD
Minimum spacing	$s_{min} \geq$ [mm]	100
Minimum edge distance	$c_{min} \geq$ [mm]	100
Minimum thickness of member	$h \geq$ [mm]	100

Scheme of distances and spacings

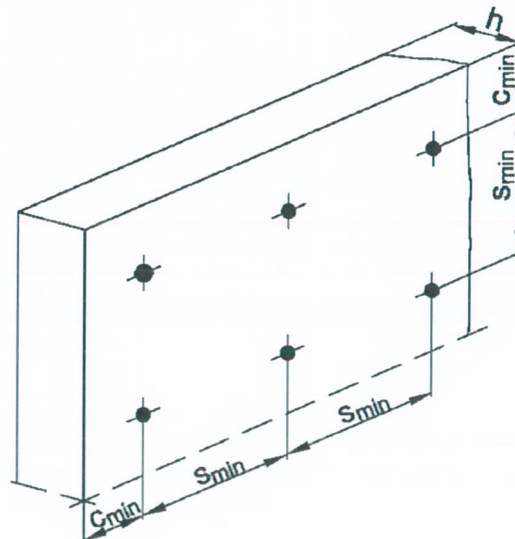

alfa Iso-Universalanchor IUD

Intended use
Installation parameters, edge distances and spacings

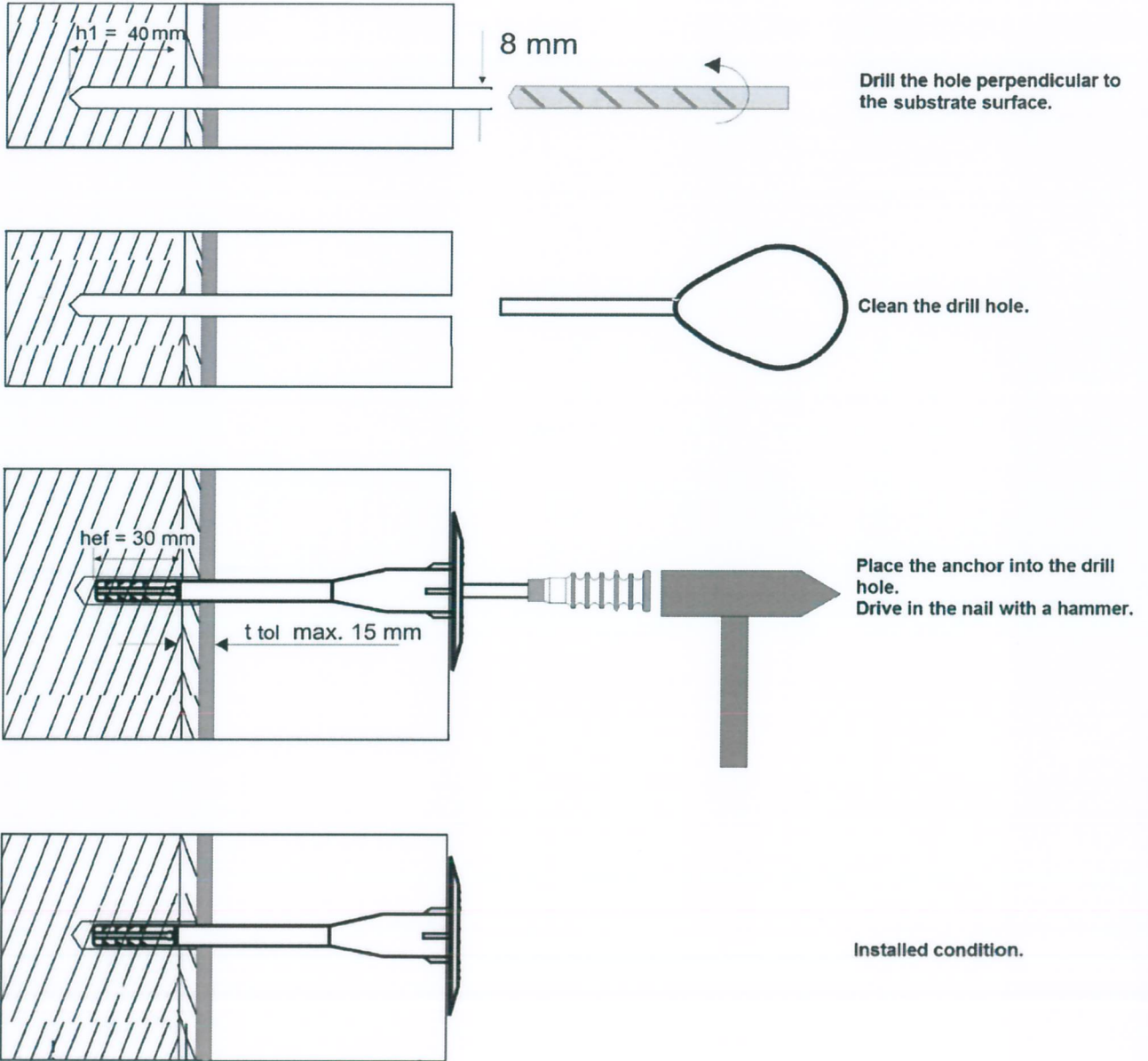

Annex B 2

Installation instructions

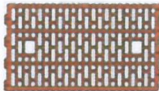

<p>allfa Iso-Universalanchor IUD</p>	<p>Annex B 3</p>
<p>Intended use Installation instructions</p>	

Table 5: Characteristic resistance to tension loads N_{Rk} in concrete and masonry for a single anchor in kN

Anchor type					alfa IUD
Base material	Bulk density ρ [kg/dm ³]	Minimum compressive strength f_b [N/mm ²]	General remarks	Drill method	N_{Rk} [kN]
Concrete C12/15 (EN 206-1:2000)				Hammer	0,75
Concrete C20/25 (EN 206-1:2000)				Hammer	1,2
Concrete C50/60 (EN 206-1:2000)	--			Hammer	1,5
Sand-lime solid bricks, KS e.g. according to EN 771-2:2011	$\geq 1,8$	12	Vertically perforation up to 15 %	Hammer	1,2
Clay bricks, Mz e.g. according to EN 771-1:2011	$\geq 2,0$	12	Vertically perforation up to 15 %	Hammer	0,9
Sand-lime perforated bricks, KSL e.g. according to EN 771-2:2011	$\geq 1,4$	12	Vertically perforation more than 15 % outer web thickness ≥ 24 mm	Hammer	0,6
Vertically perforated clay bricks, Hlz e.g. according to EN 771-1:2011	$\geq 1,0$	12	Vertically perforation ≥ 15 % and ≤ 50 %, outer web thickness ≥ 14 mm	Rotary	0,5
Vertically perforated clay bricks Hlz 25 x 38 x 23,5	$\geq 1,0$	12	 outer web thickness \geq 10,3 mm	Rotary	0,5
Lightweight aggregate concrete V e.g. according to EN 771-3:2011	$\geq 0,9$	4	 Area of grip hole \leq 10%, max. size: length 110 mm, width 45 mm	Rotary	0,4
Lightweight concrete hollow blocks Hbl e.g. according to EN 771-3:2011	$\geq 0,7$	2	Vertically perforation ≥ 15 % and ≤ 50 %, outer web thickness ≥ 30 mm	Rotary	0,5

alfa Iso-Universalanchor IUD

Performances
Characteristic resistance

Annex C 1

Table 6: Displacements allfa IUD

Base materials	Bulk density ρ [kg/dm ³]	Minimum Compressive strength f_b [N/mm ²]	Tension load N [kN]	Displacements $\delta_m(N)$ [mm]
Concrete C 12/15 C 20/25 (EN 206-1) C 50/60			0,25 0,40 0,50	1,2 1,2 1,2
Sand-lime solid bricks, KS (EN 771-2:2011)	$\geq 1,8$	12	0,40	1,3
Clay bricks, Mz (EN 771-1:2011)	$\geq 2,0$	12	0,30	1,0
Sand-lime perforated bricks, KSL (EN 771-2:2011)	$\geq 1,4$	12	0,20	0,8
Vertically perforated clay bricks, HLz (EN 771-1:2011)	$\geq 1,0$	12	0,15	0,8
Vertically perforated clay bricks, HLz 25 x 38 x 23,5 (EN 771-1:2011)	$\geq 1,0$	12	0,15	0,5
Lightweight aggregate concrete V (EN 771-3:2011)	$\geq 0,9$	4	0,13	0,5
Lightweight concrete hollow blocks Hbl (EN 771-3:2011)	$\geq 0,7$	2	0,15	0,5

Table 7: Point thermal transmittance according EOTA Technical Report TR 025:2016-05

anchor type	insulation thickness h_D [mm]	Point thermal transmittance χ [W/K]
allfa Iso- Universalanchor IUD	60 - 210	0,002

Table 8: Plate stiffness according EOTA Technical Report TR 026: 2016-05

anchor type	diameter of the anchor plate [mm]	load resistance of the anchor plate [kN]	plate stiffness [kN/mm]
allfa Iso- Universalanchor IUD	60	1,3	0,4

allfa Iso-Universalanchor IUD

Performances

Displacements, point thermal transmittance, plate stiffness

Annex C 2