



TA-Danmark A/S  
Göteborg Plads 1  
DK-2150 Nordhavn  
Tel. +45 72 24 59 00  
Fax +45 72 24 59 04  
Internet [www.etadanmark.dk](http://www.etadanmark.dk)

Authorised and notified according  
to Article 29 of the Regulation (EU)  
No 305/2011 of the European  
Parliament and of the Council of 9  
March 2011

MEMBER OF EOTA



## European Technical Assessment ETA-23/0481 of 2023/09/28

### I General Part

**Technical Assessment Body issuing the ETA and designated according to Article 29 of the Regulation (EU) No 305/2011: ETA-Danmark A/S**

**Trade name of the construction product:**

Unifix SWG screws type “WBS EVO VFT”, “WBS EVO VFT-Duo”, “WBS EVO T”, “WBS EVO VF-DUO”, “WBS EVO TC”, “WBS EVO VAB” and “WBS EVO V” screws

**Product family to which the above construction product belongs:**

Screws for use in timber constructions

**Manufacturer:**

Unifix SWG S.r.l.  
Via Enzenberg 2  
IT- 39018 Terlano (BZ)  
Tel. + 39 0471 545 200  
Fax + 39 0471 545 300  
Internet: [www.unifix.it](http://www.unifix.it)

**Manufacturing plant:**

Held on file by ETA-Danmark A/S

**This European Technical Assessment contains:**

45 pages including 5 annexes which form an integral part of the document

**This European Technical Assessment is issued in accordance with Regulation (EU) No 305/2011, on the basis of:**

European Assessment document (EAD) no. EAD 130118-01-0603 “Screws and threaded rods for timber constructions”

**This version replaces:**

The ETA with the same number issued on 2023-09-05

Translations of this European Technical Assessment in other languages shall fully correspond to the original issued document and should be identified as such.

Communication of this European Technical Assessment, including transmission by electronic means, shall be in full (excepted the confidential Annex(es) referred to above). However, partial reproduction may be made, with the written consent of the issuing Technical Assessment Body. Any partial reproduction has to be identified as such.

## II SPECIFIC PART OF THE EUROPEAN TECHNICAL ASSESSMENT

### 1 Technical description of product

#### Technical description of the product

Unifix SWG “WBS EVO VFT”, “WBS EVO VFT-Duo”, “WBS EVO T”, “WBS EVO VF-DUO“, “WBS EVO TC”, “WBS EVO VAB” and “WBS EVO V” screws are self-tapping screws to be used in timber structures. Unifix SWG “WBS EVO T”, “WBS EVO VF-DUO“, “WBS EVO VAB” screws shall be threaded over a part of the length. Unifix SWG “WBS EVO VFT” and “WBS EVO CT” screws shall be threaded over the full length. Unifix SWG “WBS EVO V” screws may be threaded over a part or over the full length. “WBS EVO VFT-Duo” screws have two threads, one close to the tip and one close to the head. The screws shall be produced from carbon steel wire for nominal diameters of 3,5 mm to 12,0 mm and from stainless steel wire for nominal diameters of 3,5 mm to 10,0 mm. Where corrosion protection is required, the material or coating shall be declared in accordance with the relevant specification given in Annex A of EN 14592.

#### Geometry and Material

The nominal diameter (outer thread diameter),  $d$ , shall not be less than 3,5 mm and shall not be greater than 12,0 mm. The overall length,  $L$ , of screws shall not be less than 25 mm and shall not be greater than 1000 mm. Other dimensions are given in Annex A.

The ratio of inner thread diameter to outer thread diameter  $d_i/d$  ranges from 0,57 to 0,77.

The screws are threaded over a minimum length  $\ell_g$  of  $4 \cdot d$  (i.e.  $\ell_g \geq 4 \cdot d$ ).

The lead  $p$  (distance between two adjacent thread flanks) ranges from  $0,38 \cdot d$  to  $0,97 \cdot d$ .

No breaking shall be observed at a bend angle,  $\alpha$ , of less than  $(45/d^{0,7} + 20)$  degrees.

### 2 Specification of the intended use in accordance with the applicable European Assessment Document (hereinafter EAD)

The screws are used for connections in load bearing timber structures between members of solid timber (softwood), glued laminated timber, cross-laminated timber, and laminated veneer lumber (softwood and hardwood), similar glued members, wood-based panels or steel. Unifix SWG “WBS EVO VFT” screws are also

used as tensile or compressive reinforcement perpendicular to the grain.

Furthermore Unifix SWG screws with diameters between 6 mm and 12 mm may also be used for the fixing of thermal insulation on rafters.

Steel plates and wood-based panels except solid wood panels, LVL and cross laminated timber shall only be located on the side of the screw head. The following wood-based panels may be used:

- Plywood according to EN 636 or ETA
- Particleboard according to EN 312 or ETA
- Oriented Strand Board, Type OSB/3 and OSB/4 according to EN 300 or ETA
- Fibreboard according to EN 622-2 and 622-3 or ETA (minimum density 650 kg/m<sup>3</sup>)
- Cement bonded particleboard
- Solid wood panels according to EN 13353 and EN 13986 and cross laminated timber according to ETA
- Laminated Veneer Lumber, LVL
- FST according to ETA-14/0354
- Engineered wood products according to ETA, provided that the ETA for the product provides provisions for the use of self-tapping screws and these provisions are applied

The screws shall be driven into the wood without pre-drilling or after pre-drilling with a diameter not larger than the inner thread diameter for the length of the threaded part and with a maximum of the smooth shank diameter for the length of the smooth shank. The stainless steel WBS EVO VFT screws shall be driven into softwood after pre-drilling with the following diameter:

WBS EVO VFT 10 mm austenitic stainless steel: Pre-drilling diameter 6 mm.

10 mm WBS EVO VFT screws made from stainless steel shall only be driven into pre-drilled holes.

The screws are intended to be used in timber connections for which requirements for mechanical resistance and stability and safety in use in the sense of the Basic Works Requirements 1 and 4 of Regulation 305/2011 (EU) shall be fulfilled.

The design of the connections shall be based on the characteristic load-carrying capacities of the screws. The design capacities shall be derived from the characteristic capacities in accordance with Eurocode 5 or an appropriate national code.

The screws are intended for use for connections subject to static or quasi static loading.

Section 3.11 of this ETA contains the corrosion protection for Unifix SWG screws made from carbon steel and the material number of the stainless steel. The martensitic stainless steel screws are for use in timber structures subject to the conditions defined by the service classes 1, 2 and 3 of EN 1995-1-1 (Eurocode 5).

The scope of the screws regarding resistance to corrosion shall be defined according to national provisions that apply at the installation site considering environmental conditions.

The provisions made in this European Technical Assessment are based on an assumed intended working life of the screws of 50 years.

The indications given on the working life cannot be interpreted as a guarantee given by the producer or Assessment Body, but are to be regarded only as a means for choosing the right products in relation to the expected economically reasonable working life of the works.

### 3 Performance of the product and references to the methods used for its assessment

Characteristic	Assessment of characteristic
<b>3.1 Mechanical resistance and stability*) (BWR1)</b>	
Tensile strength	Characteristic value $f_{\text{tens,k}}$ :
Screws made of carbon steel or stainless steel	Screw d = 3,5 mm: 3,8 kN
hardened (martensitic stainless steel) except WBS	Screw d = 4,0 mm: 5,0 kN
EVO VFT, WBS EVO VFT-Duo and WBS EVO V	Screw d = 4,5 mm: 6,4 kN
	Screw d = 5,0 mm: 7,9 kN
	Screw d = 6,0 mm: 11 kN
	Screw d = 8,0 mm: 20 kN
	Screw d = 10,0 mm: 28 kN
	Screw d = 12,0 mm: 25 kN
WBS EVO VFT and WBS EVO VFT-Duo screws made of carbon steel	Screw d = 6,5 mm: 17 kN
	Screw d = 8,0 mm: 25 kN
	Screw d = 9,0 mm: 30 kN
	Screw d = 10,0 mm: 33 kN
	Screw d = 11,3 mm: 50 kN
WBS EVO V screws made of carbon steel	Screw d = 8,0 mm: 30 kN
Screws made of stainless steel unhardened (austenitic stainless steel A2 and A4)	Screw d = 3,5 mm: 2,1 kN
	Screw d = 4,0 mm: 2,8 kN
	Screw d = 4,5 mm: 3,5 kN
	Screw d = 5,0 mm: 4,3 kN
	Screw d = 6,0 mm: 6,2 kN
	Screw d = 6,5 mm: 10 kN
	Screw d = 8,0 mm: 11 kN
	Screw d = 10,0 mm: 20 kN
WBS EVO VFT screws made of stainless steel unhardened (austenitic stainless steel A2 and A4)	Screw d = 6,5 mm: 10 kN
	Screw d = 8,0 mm: 14 kN
	Screw d = 10,0 mm: 20 kN
Insertion moment	Ratio of the characteristic torsional strength to the mean insertion moment: $f_{\text{tor,k}} / R_{\text{tor,mean}} \geq 1,5$
Torsional strength	Characteristic value $f_{\text{tor,k}}$ :
Screws made of carbon steel or stainless steel	Screw d = 3,5 mm: 2,0 Nm
hardened (martensitic stainless steel) except WBS	Screw d = 4,0 mm: 3,0 Nm
EVO VFT, WBS EVO VFT-Duo and WBS EVO V	Screw d = 4,5 mm: 4,2 Nm
	Screw d = 5,0 mm: 5,6 Nm
	Screw d = 6,0 mm: 9,5 Nm
	Screw d = 8,0 mm: 22 Nm
	Screw d = 10,0 mm: 40 Nm
	Screw d = 12,0 mm: 42 Nm
WBS EVO VFT and s WBS EVO VFT-Duo crews made of carbon steel	Screw d = 6,5 mm: 19 Nm
	Screw d = 8,0 mm: 28 Nm
	Screw d = 9,0 mm: 51 Nm
	Screw d = 10,0 mm: 48 Nm
	Screw d = 11,3 mm: 80 Nm
WBS EVO V screws made of carbon steel	Screw d = 8,0 mm: 40 Nm

<b>Characteristic</b>	<b>Assessment of characteristic</b>
Screws made of stainless steel unhardened (austenitic stainless steel A2 and A4)	Screw d = 3,5 mm: 1,2 Nm Screw d = 4,0 mm: 1,8 Nm Screw d = 4,5 mm: 2,5 Nm Screw d = 5,0 mm: 3,4 Nm Screw d = 6,0 mm: 5,7 Nm Screw d = 6,5 mm: 10,0 Nm Screw d = 8,0 mm: 13,0 Nm Screw d = 10,0 mm: 28,0 Nm
WBS EVO VFT screws made of stainless steel unhardened (austenitic stainless steel A2 and A4)	Screw d = 6,5 mm: 11 Nm Screw d = 8,0 mm: 16 Nm Screw d = 10,0 mm: 28 Nm

### 3.2 Safety in case of fire (BWR2)

Reaction to fire

The screws are made from steel classified as performance class A1 of the characteristic reaction to fire, in accordance with the provisions of EC decision 96/603/EC, amended by EC Decision 2000/605/EC.

### 3.3 General aspects related to the performance of the product

The screws have been assessed as having satisfactory durability and serviceability when used in timber structures using the timber species described in Eurocode 5 and subject to the conditions defined by service classes 1, 2 and 3

Identification

See Annex A

\*) See additional information in section 3.4 – 3.6.

### 3.4 Mechanical resistance and stability

The load-carrying capacities for Unifix SWG screws are applicable to the wood-based materials mentioned in paragraph 1 even though the term timber has been used in the following.

The characteristic lateral load-carrying capacities and the characteristic axial withdrawal capacities of Unifix SWG screws should be used for designs in accordance with Eurocode 5 or an appropriate national code.

Point side penetration length must be  $l_{ef} \geq 4 \cdot d$ , where  $d$  is the outer thread diameter of the screw. For the fixing of rafters, point side penetration must be at least 40 mm,  $l_{ef} \geq 40$  mm.

ETA's for structural members or wood-based panels must be considered where applicable.

#### Lateral load-carrying capacity

The characteristic lateral load-carrying capacity of Unifix SWG screws shall be calculated according to Eurocode 5 using the outer thread diameter  $d$  as the nominal diameter of the screw. The contribution from the rope effect may be considered.

For steel-to-timber connections with "WBS EVO TC" screws  $d = 5$  mm, a thick steel plate may be assumed for steel plate thickness  $t \geq 2,0$  mm.

The characteristic yield moment shall be calculated from:

Unifix SWG screws for  $3,5 \text{ mm} \leq d \leq 10,0 \text{ mm}$  made of carbon steel or stainless steel hardened martensitic stainless steel except WBS EVO VFT and WBS EVO VFT-Duo :

$$M_{y,k} = 0,15 \cdot 600 \cdot d^{2,6} \quad [\text{Nmm}]$$

WBS EVO T screws:

$$\text{Screw } d = 12,0 \text{ mm: } 40000 \text{ Nmm}$$

Unifix SWG WBS EVO VFT and WBS EVO VFT-Duo screws made of carbon steel:

$$\text{Screw } d = 6,5 \text{ mm: } 15000 \text{ Nmm}$$

$$\text{Screw } d = 8,0 \text{ mm: } 25000 \text{ Nmm}$$

$$\text{Screw } d = 9,0 \text{ mm: } 40000 \text{ Nmm}$$

$$\text{Screw } d = 10,0 \text{ mm: } 40000 \text{ Nmm}$$

$$\text{Screw } d = 11,3 \text{ mm: } 70000 \text{ Nmm}$$

Unifix SWG WBS EVO V screws:

$$\text{Screw } d = 8,0 \text{ mm: } 35000 \text{ Nmm}$$

Unifix SWG screws for  $3,5 \text{ mm} \leq d \leq 10,0 \text{ mm}$  made of stainless steel (austenitic stainless steel A2 and A4) except WBS EVO VFT:

$$M_{y,k} = 0,15 \cdot 320 \cdot d^{2,6} \quad [\text{Nmm}]$$

Unifix SWG WBS EVO VFT screws made of austenitic stainless steel:

$$\text{Screw } d = 6,5 \text{ mm: } 10000 \text{ Nmm}$$

$$\text{Screw } d = 8,0 \text{ mm: } 16000 \text{ Nmm}$$

$$\text{Screw } d = 10,0 \text{ mm: } 26000 \text{ Nmm}$$

where

$d$  outer thread diameter [mm]

The embedding strength for screws in non-pre-drilled holes in softwood arranged at an angle between screw axis and grain direction,  $0^\circ \leq \alpha \leq 90^\circ$  is:

$$f_{h,k} = \frac{0,082 \cdot \rho_k \cdot d^{-0,3}}{2,5 \cdot \cos^2 \alpha + \sin^2 \alpha} \quad [\text{N/mm}^2]$$

and accordingly for screws in pre-drilled holes:

$$f_{h,k} = \frac{0,082 \cdot \rho_k \cdot (1 - 0,01 \cdot d)}{2,5 \cdot \cos^2 \alpha + \sin^2 \alpha} \quad [\text{N/mm}^2]$$

Where

$\rho_k$  characteristic timber density [ $\text{kg/m}^3$ ];

$d$  outer thread diameter [mm];

$\alpha$  angle between screw axis and grain direction.

The embedding strength for screws arranged parallel to the plane of cross laminated timber, independent of the angle between screw axis and grain direction,  $0^\circ \leq \alpha \leq 90^\circ$ , may be calculated from:

$$f_{h,k} = 20 \cdot d^{-0,5} \quad [\text{N/mm}^2]$$

Where

$d$  outer thread diameter [mm]

The embedding strength for screws or threaded rods in the wide face of cross laminated timber should be assumed as for solid timber based on the characteristic density of the outer layer. If relevant, the angle between force and grain direction of the outer layer should be taken into account.

The direction of the lateral force shall be perpendicular to the screw axis and parallel to the wide face of the cross laminated timber.

The embedding strength for screws in non-pre-drilled holes in softwood LVL arranged at an angle between screw axis and grain direction,  $0^\circ \leq \alpha \leq 90^\circ$  is:

$$f_{h,k} = \frac{0,082 \cdot \rho_k \cdot d^{-0,3}}{(2,5 \cdot \cos^2 \alpha + \sin^2 \alpha)(1,5 \cdot \cos^2 \beta + \sin^2 \beta)} \quad [\text{N/mm}^2]$$

and accordingly for screws in pre-drilled holes in softwood LVL:

$$f_{h,k} = \frac{0,082 \cdot \rho_k \cdot (1 - 0,01 \cdot d)}{(2,5 \cdot \cos^2 \alpha + \sin^2 \alpha)(1,5 \cdot \cos^2 \beta + \sin^2 \beta)} \quad [\text{N/mm}^2]$$

Where

$\rho_k$  characteristic timber density [ $\text{kg/m}^3$ ];

$d$  outer thread diameter [mm];

- $\alpha$  angle between screw axis and grain direction;  
 $\beta$  angle between screw axis and the LVL's wide face  
 $(0^\circ \leq \alpha \leq 90^\circ)$ .

The embedding strength for screws in pre-drilled or non-pre-drilled holes in Beech LVL according to EN 14374 or in FST according to ETA-14/0354 is:

$$f_{h,k} = \frac{0,082 \cdot \rho_k \cdot d^{-0,15}}{(2,5 \cdot \cos^2 \alpha + \sin^2 \alpha) \cdot k_\varepsilon \cdot k_\beta} \quad [\text{N/mm}^2]$$

Where

- $\rho_k$  characteristic density [ $\text{kg/m}^3$ ];  
 $d$  outer thread diameter [mm];  
 $\alpha$  angle between screw axis and grain direction,  
 $0^\circ \leq \alpha \leq 90^\circ$ ;  
 $k_\varepsilon = (0,5 + 0,024 \cdot d) \cdot \sin^2 \varepsilon + \cos^2 \varepsilon$ ;  
 $\varepsilon$  angle between load and grain direction;  
 $0^\circ \leq \varepsilon \leq 90^\circ$ ;  
 $k_\beta = 1,2 \cdot \cos^2 \beta + \sin^2 \beta$ ;  
 $\beta$  angle between screw axis and wide face of LVL or FST member,  $0^\circ \leq \beta \leq 90^\circ$ .

### Axial withdrawal capacity

The characteristic axial withdrawal capacity of Unifix SWG screws in solid timber (softwood), glued laminated timber or cross-laminated timber members at an angle of  $0^\circ \leq \alpha \leq 90^\circ$  (except WBS EVO T or WBS EVO VFT screws in Beech LVL or FST according to ETA-14/0354) to the grain shall be calculated from:

$$F_{ax,\alpha,Rk} = \frac{n_{ef} \cdot k_{ax} \cdot f_{ax,k} \cdot d \cdot \ell_{ef} \left( \frac{\rho_k}{\rho_a} \right)^{0,8}}{k_\beta} \quad [\text{N}]$$

Where

- $F_{ax,\alpha,Rk}$  characteristic withdrawal capacity of the group of screws at an angle  $\alpha$  to the grain [N]  
 $n_{ef}$  effective number of screws according to EN 1995-1-1:2008  
 $k_{ax} = 1,0$  for  $45^\circ \leq \alpha \leq 90^\circ$   
 $k_{ax} = a + \frac{b \cdot \alpha}{45^\circ}$  for  $0^\circ \leq \alpha < 45^\circ$   
 $a = \begin{cases} 0,5 & \text{for LVL or FST} \\ 0,3 & \text{for timber} \end{cases}$   
 $b = \begin{cases} 0,5 & \text{for LVL or FST} \\ 0,7 & \text{for timber} \end{cases}$   
 $k_\beta = 1,0$  for timber  
 $k_\beta = 1,5 \cdot \cos^2 \beta + \sin^2 \beta$  for LVL or FST  
 $f_{ax,k}$  Characteristic withdrawal parameter  
Screws except WBS EVO VFT-Duo  $d = 6,5$  mm in softwood and  $\rho_a = 350 \text{ kg/m}^3$ :  
Screw  $d = 3,5$  mm:  $f_{ax,k} = 13,3 \text{ N/mm}^2$   
Screw  $d = 4,0$  mm:  $f_{ax,k} = 12,9 \text{ N/mm}^2$   
Screw  $d = 4,5$  mm:  $f_{ax,k} = 12,5 \text{ N/mm}^2$   
Screw  $d = 5,0$  mm:  $f_{ax,k} = 12,1 \text{ N/mm}^2$   
Screw  $d = 6,0$  mm:  $f_{ax,k} = 11,4 \text{ N/mm}^2$   
Screw  $d = 6,5$  mm:  $f_{ax,k} = 11,4 \text{ N/mm}^2$

- Screw  $d = 8,0$  mm:  $f_{ax,k} = 11,1 \text{ N/mm}^2$   
WBS EVO VFT-Duo screw  
 $d = 6,5$  mm  $f_{ax,k} = 4,0 \text{ N/mm}^2$   
Screw  
 $d \geq 10,0$  mm:  $f_{ax,k} = 10,8 \text{ N/mm}^2$

WBS EVO T or WBS EVO VFT screws in softwood LVL and  $\rho_a = 500 \text{ kg/m}^3$ :  
Screw  $5 \text{ mm} \leq d \leq 12 \text{ mm}$ :  $f_{ax,k} = 15 \text{ N/mm}^2$

WBS EVO T, WBS EVO V or WBS EVO VFT screws in pre-drilled hardwood LVL or FST (ETA-14/0354) and  $\rho_a = 730 \text{ kg/m}^3$ :  
Screw  $5 \text{ mm} \leq d \leq 7 \text{ mm}$ :  $f_{ax,k} = 32 \text{ N/mm}^2$   
Screw  $8 \text{ mm} \leq d \leq 10 \text{ mm}$ :  $f_{ax,k} = 25 \text{ N/mm}^2$

WBS EVO V screws in non-pre-drilled hardwood LVL or FST (ETA-14/0354) and  $\rho_a = 730 \text{ kg/m}^3$ :  
Screw  $d = 8,0$  mm:  $f_{ax,k} = 30 \text{ N/mm}^2$

- $d$  outer thread diameter [mm]  
 $\ell_{ef}$  point or head side penetration length of the threaded part excluding the head according to EN 1995-1-1:2008 [mm]  
 $\alpha$  angle between grain and screw axis ( $\alpha \geq 30^\circ$  for screws with tip type PA)  
 $\beta$  angle between screw axis and the LVL's wide face ( $0^\circ \leq \alpha \leq 90^\circ$ )  
 $\rho_k$  characteristic density [ $\text{kg/m}^3$ ]  
 $\rho_a$  associated density for  $f_{ax,k}$  [ $\text{kg/m}^3$ ]

For screws penetrating more than one layer of cross laminated timber, the different layers may be taken into account proportionally.

The axial withdrawal capacity is limited by the head pull-through capacity and the tensile or compressive capacity of the screw.

### Head pull-through capacity

The characteristic head pull-through capacity of Unifix SWG screws shall be calculated according to EN 1995-1-1:2008 from:

$$F_{ax,\alpha,Rk} = n_{ef} \cdot f_{head,k} \cdot d_h^2 \cdot \left( \frac{\rho_k}{350} \right)^{0,8} \quad [\text{N}]$$

where:

- $F_{ax,\alpha,Rk}$  characteristic head pull-through capacity of the connection at an angle  $\alpha \geq 30^\circ$  to the grain [N]  
 $n_{ef}$  effective number of screws according to EN 1995-1-1:2008  
 $f_{head,k}$  characteristic head pull-through parameter [ $\text{N/mm}^2$ ]  
 $d_h$  diameter of the screw head [mm]  
 $\rho_k$  characteristic density [ $\text{kg/m}^3$ ], for wood-based panels  $\rho_k = 380 \text{ kg/m}^3$

Characteristic head pull-through parameter for Unifix SWG screws with head type TSC in connections with timber and in connections with wood-based panels with thicknesses above 20 mm:

$$f_{\text{head,k}} = 10,0 \text{ N/mm}^2$$

Characteristic head pull-through parameter for Unifix SWG screws except screws with head type TSC in connections with timber and in connections with wood-based panels with thicknesses above 20 mm:

$$f_{\text{head,k}} = 12,0 \text{ N/mm}^2$$

Characteristic head pull-through parameter for WBS EVO T, WBS EVO V or WBS EVO VFT screws with a head diameter  $d_h \leq 25$  mm in connections with LVL and FST (ETA-14/0354) members with characteristic density  $700 \text{ kg/m}^3 \leq \rho_k \leq 750 \text{ kg/m}^3$  with thicknesses of at least 40 mm:

$$f_{\text{head,k}} = 47 - 1,5 \cdot d_h \text{ N/mm}^2$$

Characteristic head pull-through parameter for screws in connections with wood-based panels with thicknesses between 12 mm and 20 mm:

$$f_{\text{head,k}} = 8 \text{ N/mm}^2$$

Screws in connections with wood-based panels with a thickness below 12 mm (minimum thickness of the wood based panels of  $1,2 \cdot d$  with  $d$  as outer thread diameter):

$$f_{\text{head,k}} = 8 \text{ N/mm}^2$$

limited to  $F_{\text{ax,Rk}} = 400 \text{ N}$

For “WBS EVO VFT” or “WBS EVO V” screws, the withdrawal capacity of the thread in the member with the screw head may be taken into account instead of the head pull-through capacity.

The head diameter  $d_h$  shall be greater than  $1,8 \cdot d_s$ , where  $d_s$  is the smooth shank or the wire diameter. Otherwise the characteristic head pull-through capacity  $F_{\text{ax},\alpha,\text{Rk}} = 0$ .

The minimum thickness of wood-based panels according to the clause 2.1 must be observed.

In steel-to-timber connections the head pull-through capacity may be disregarded.

### Tensile capacity

The characteristic tensile strength  $f_{\text{tens,k}}$  of Unifix SWG screws made of carbon steel or martensitic stainless steel 1.4006 except WBS EVO VFT, WBS EVO VFT-Duo or WBS EVO V is:

Screw d = 3,5 mm:	3,8 kN
Screw d = 4,0 mm:	5,0 kN
Screw d = 4,5 mm:	6,4 kN
Screw d = 5,0 mm:	7,9 kN
Screw d = 6,0 mm:	11 kN
Screw d = 8,0 mm:	20 kN
Screw d = 10,0 mm:	28 kN
Screw d = 12,0 mm:	25 kN

The characteristic tensile strength  $f_{\text{tens,k}}$  of Unifix SWG WBS EVO VFT and WBS EVO VFT-Duo screws made of carbon steel is:

Screw d = 6,5 mm:	17 kN
Screw d = 8,0 mm:	25 kN
Screw d = 9,0 mm:	30 kN
Screw d = 10,0 mm:	33 kN
Screw d = 11,3 mm:	50 kN

The characteristic tensile strength  $f_{\text{tens,k}}$  of Unifix SWG WBS EVO V screws made of carbon steel is:

Screw d = 8 mm:	30 kN
-----------------	-------

The characteristic tensile strength  $f_{\text{tens,k}}$  of Unifix SWG screws made of stainless steel (austenitic stainless steel A2 and A4) except WBS EVO VFT is:

Screw d = 3,5 mm:	2,1 kN
Screw d = 4,0 mm:	2,8 kN
Screw d = 4,5 mm:	3,5 kN
Screw d = 5,0 mm:	4,3 kN
Screw d = 6,0 mm:	6,2 kN
Screw d = 8,0 mm:	11 kN
Screw d = 10,0 mm:	20 kN

The characteristic tensile strength  $f_{\text{tens,k}}$  of Unifix SWG WBS EVO VFT screws made of austenitic stainless steel is:

Screw d = 6,5 mm:	10 kN
Screw d = 8,0 mm:	14 kN
Screw d = 10,0 mm:	20 kN

For screws used in combination with steel plates, the tear-off capacity of the screw head should be greater than the tensile strength of the screw.

### Compressive capacity

The characteristic buckling capacity  $F_{\text{ki,Rk}}$  of Unifix SWG “WBS EVO VFT” or “WBS EVO V” screws embedded in timber shall be calculated from:

$$F_{\text{ki,Rk}} = \kappa_c \cdot N_{\text{pl,k}} \quad [\text{N}]$$

where

$$\kappa_c = \begin{cases} 1 & \text{for } \bar{\lambda}_k \leq 0,2 \\ \frac{1}{k + \sqrt{k^2 - \bar{\lambda}_k^2}} & \text{for } \bar{\lambda}_k > 0,2 \end{cases}$$

$$k = 0,5 \cdot \left[ 1 + 0,49 \cdot (\bar{\lambda}_k - 0,2) + \bar{\lambda}_k^2 \right]$$

The relative slenderness ratio shall be calculated from:

$$\bar{\lambda}_k = \sqrt{\frac{N_{\text{pl,k}}}{N_{\text{ki,k}}}}$$

Where

$$N_{pl,k} = \pi \cdot \frac{d_1^2}{4} \cdot f_{y,k} \quad [N]$$

is the characteristic value for the axial capacity in case of plastic analysis referred to the inner thread cross section.

Characteristic yield strength:

$f_{y,k} = 1000$  [N/mm<sup>2</sup>] for WBS EVO VFT or WBS EVO V screws  
made of carbon steel or stainless steel hardened (martensitic stainless steel)

$f_{y,k} = 500$  [N/mm<sup>2</sup>] for WBS EVO VFT screws made of stainless steel unhardened (austenitic stainless steel A2 and A4)

Characteristic ideal elastic buckling load:

$$N_{ki,k} = \sqrt{c_h \cdot E_s \cdot I_s} \quad [N]$$

Elastic foundation of the screw:

$$c_h = (0,19 + 0,012 \cdot d) \cdot \rho_k \cdot \left( \frac{\alpha}{180^\circ} + 0,5 \right) \quad [N/mm^2]$$

Modulus of elasticity:

$$E_s = 205000 \quad [N/mm^2]$$

Second moment of area:

$$I_s = \frac{\pi}{64} \cdot d_1^4 \quad [mm^4]$$

$d_1$  = inner thread diameter [mm]

$\alpha$  = angle between screw axis and grain direction [°]

Note: When determining design values of the compressive capacity it should be considered that  $f_{ax,d}$  is to be calculated using  $k_{mod}$  and  $\gamma_M$  for timber according to EN 1995 while  $N_{pl,d}$  is calculated using  $\gamma_{M,0}$  for steel according to EN 1993.

### Mechanically jointed beams

“WBS EVO VFT” or “WBS EVO V” screws with a full thread may be used for connections in structural members which are composed of several parts in mechanically jointed beams or columns.

The axial slip modulus  $K_{ser}$  of a screw or threaded rod with a full thread for the serviceability limit state should be taken independent of angle  $\alpha$  to the grain as:

$$C = K_{ser} = 25 \cdot d \cdot \ell_{ef} \quad [N/mm] \text{ for screws in softwood}$$

$$C = K_{ser} = 30 \cdot d \cdot \ell_{ef} \quad [N/mm] \text{ for screws in hardwood}$$

Where

$d$  outer thread diameter [mm]

$\ell_{ef}$  penetration length in the structural member [mm] (see Annex B)

### Combined laterally and axially loaded screws

For screwed connections subjected to a combination of axial and lateral load, the following expression should be satisfied:

$$\left( \frac{F_{ax,Ed}}{F_{ax,Rd}} \right)^2 + \left( \frac{F_{la,Ed}}{F_{la,Rd}} \right)^2 \leq 1$$

where

$F_{ax,Ed}$  axial design load of the screw

$F_{la,Ed}$  lateral design load of the screw

$F_{ax,Rd}$  design load-carrying capacity of an axially loaded screw

$F_{la,Rd}$  design load-carrying capacity of a laterally loaded screw.

## 3.5 Aspects related to the performance of the product

### 3.5.1 Corrosion protection in service class 1, 2 and 3.

The Unifix SWG screws with nominal diameters of 3,5 mm to 12,0 mm are produced from carbon wire. Screws made from carbon steel are electrogalvanised or otherwise coated appropriate for the expected working life and service class. The mean thickness of the zinc coating is 5µm.

Screws with nominal diameters of 3,5 mm to 10,0 mm are produced from hardened stainless steel no. 1.4006 or unhardened stainless steel no. 1.4301, 1.4401, 1.4567 and 1.4578.

## 3.6 General aspects related to the intended use of the product

The screws are manufactured in accordance with the provisions of the European Technical Assessment using the automated manufacturing process and laid down in the technical documentation.

The installation shall be carried out in accordance with Eurocode 5 or an appropriate national code unless otherwise is defined in the following. Instructions from Unifix SWG S.r.l. should be considered for installation.

The screws are used for connections in load bearing timber structures between members of solid timber (softwood), glued laminated timber, cross-laminated timber, and laminated veneer lumber, similar glued members, wood-based panels or steel members.

The screws may be used for connections in load bearing timber structures with structural members according to an associated ETA, if according to the associated ETA of the structural member a connection in load bearing timber structures with screws according to a ETA is allowed.

Unifix SWG fully threaded „WBS EVO VFT” or “WBS EVO V” screws are also used as tensile or compressive reinforcement perpendicular to the grain.

Furthermore the screws with diameters of at least 6 mm may also be used for the fixing of insulation on top of rafters.

A minimum of two screws should be used for connections in load bearing timber structures.

For screws arranged under an angle between screw axis and grain direction of less than  $90^\circ$ , the minimum penetration depth of the screw tip is:

$$l_{ef} \geq \min(4 \cdot d / \sin \alpha ; 20 \cdot d).$$

Wood-based panels and steel plates should only be arranged on the side of the screw head. The minimum thickness of wood-based panels should be  $1,2 \cdot d$ . Furthermore the minimum thickness for following wood-based panels should be:

- Plywood, Fibreboards: 6 mm
- Particleboards, OSB, Cement Particleboards: 8 mm
- Solid wood panels: 12 mm

For structural members according to ETA's the terms of the ETA's must be considered.

If screws with an outer thread diameter  $d \geq 8$  mm are used in load bearing timber structures, the structural solid or glued laminated timber, laminated veneer lumber and similar glued members must be from spruce, pine or fir. This does not apply for screws in pre-drilled holes or for screws with tip type PARFI in non-predrilled holes.

The minimum angle between the screw axis of screws and the grain direction  $0^\circ \leq \alpha \leq 90^\circ$ .

The screws shall be driven into the wood with or without pre-drilling. The maximum pre-drilling diameter is the inner thread diameter for the length of the threaded part and the smooth shank diameter for the depth of the smooth shank.

The drill hole diameters are:

Outer thread diameter [mm]	Drill hole diameter [mm]	
	Softwood	Beech LVL or FST
4,0	2,5	-
4,5	2,5	-
5,0	3,0	3,5
6,0	4,0	4,5
6,5	4,0	5,0
8,0	5,0	6,0
10,0	6,0	8,0
12,0	7,0	-

The hole diameter in steel members must be predrilled with a suitable diameter.

Only the equipment prescribed by Unifix SWG S.r.l. shall be used for driving the screws.

In connections with screws with countersunk head according to Annex A the head must be flush with the surface of the connected structural member. A deeper countersink is not allowed.

For structural timber members, minimum spacing and distances for screws in predrilled holes are given in Eurocode 5 clause 8.3.1.2 and table 8.2 as for nails in predrilled holes. Here, the outer thread diameter  $d$  must be considered.

For screws in non-predrilled holes, minimum spacing and distances are given in Eurocode 5 clause 8.3.1.2 and table 8.2 as for nails in non-predrilled holes.

For Douglas fir members minimum spacing and distances parallel to the grain shall be increased by 50%.

Minimum distances from loaded or unloaded ends must be  $15 \cdot d$  for screws in non-predrilled holes with outer thread diameter  $d \geq 8$  mm and timber thickness  $t < 5 \cdot d$ .

Minimum distances from the unloaded edge perpendicular to the grain may be reduced to  $3 \cdot d$  also for timber thickness  $t < 5 \cdot d$ , if the spacing parallel to the grain and the end distance is at least  $25 \cdot d$ .

Minimum distances and spacing for exclusively axially loaded screws in non-predrilled holes in members with a minimum thickness  $t = 10 \cdot d$  and a minimum width of  $8 \cdot d$  or 60 mm, whichever is the greater, may be taken as:

$$\begin{aligned} \text{Spacing } a_1 \text{ parallel to the grain} & a_1 = 5 \cdot d \\ \text{Spacing } a_2 \text{ perpendicular to the grain} & a_2 = 5 \cdot d \\ \text{Distance } a_{1,c} \text{ from centre of the screw-part in} & \\ \text{timber to the end grain} & a_{1,c} = 10 \cdot d \\ \text{Distance } a_{2,c} \text{ from centre of the screw-part in} & \\ \text{timber to the edge} & a_{2,c} = 4 \cdot d \end{aligned}$$

Spacing  $a_2$  perpendicular to the grain may be reduced from  $5 \cdot d$  to  $2,5 \cdot d$ , if the condition  $a_1 \cdot a_2 \geq 25 \cdot d^2$  is fulfilled.

Minimum distances and spacing for 8 mm "WBS EVO V" screws in non-predrilled holes in Beech LVL or FST members with a minimum thickness  $t = 14 \cdot d$  and a minimum width of  $14 \cdot d$  may be taken as:

$$\begin{aligned} \text{Spacing } a_1 \text{ parallel to the grain} & a_1 = 15 \cdot d \\ \text{Spacing } a_2 \text{ perpendicular to the grain} & a_2 = 7 \cdot d \\ \text{Loaded end distance } a_{3,t} & a_{3,t} = 20 \cdot d \\ \text{Unloaded end distance } a_{3,c} & a_{3,t} = 15 \cdot d \\ \text{Loaded edge distance } a_{4,t} & a_{3,t} = 10 \cdot d \\ \text{Unloaded edge distance } a_{4,c} & a_{3,t} = 7 \cdot d \end{aligned}$$

Minimum distances and spacing for exclusively axially loaded screws in predrilled holes or for screws with tip type PARFI in non-predrilled holes in members with a minimum thickness  $t = 10 \cdot d$  and a minimum width of  $8 \cdot d$  or 60 mm, whichever is the greater, may be taken as:

$$\begin{aligned} \text{Spacing } a_1 \text{ parallel to the grain} & a_1 = 5 \cdot d \\ \text{Spacing } a_2 \text{ perpendicular to the grain} & a_2 = 5 \cdot d \\ \text{Distance } a_{1,c} \text{ from centre of the screw-part in} & \\ \text{timber to the end grain} & a_{1,c} = 5 \cdot d \\ \text{Distance } a_{2,c} \text{ from centre of the screw-part in} & \\ \text{timber to the edge} & a_{2,c} = 3 \cdot d \end{aligned}$$

Spacing  $a_2$  perpendicular to the grain may be reduced from  $5 \cdot d$  to  $2,5 \cdot d$ , if the condition  $a_1 \cdot a_2 \geq 25 \cdot d^2$  is fulfilled.

For a crossed screw couple the minimum spacing between the crossing screws is  $1,5 \cdot d$ .

Minimum thickness for structural members is  $t = 24$  mm for screws with outer thread diameter  $d < 8$  mm,  $t = 30$  mm for screws with outer thread diameter  $d = 8$  mm, and  $t = 40$  mm for screws with outer thread diameter  $d = 10$  mm.

Unless specified otherwise in the technical specification (ETA or hEN) of cross laminated timber, minimum distances and spacing for screws in the wide face of cross laminated timber members with a minimum thickness  $t = 10 \cdot d$  may be taken as (see Annex B):

Spacing $a_1$ parallel to the grain	$a_1 = 4 \cdot d$
Spacing $a_2$ perpendicular to the grain	$a_2 = 2,5 \cdot d$
Distance $a_{3,c}$ from centre of the screw-part in timber to the unloaded end grain	$a_{3,c} = 6 \cdot d$
Distance $a_{3,t}$ from centre of the screw-part in timber to the loaded end grain	$a_{3,t} = 6 \cdot d$
Distance $a_{4,c}$ from centre of the screw-part in timber to the unloaded edge	$a_{4,c} = 2,5 \cdot d$
Distance $a_{4,t}$ from centre of the screw-part in timber to the loaded edge	$a_{4,t} = 6 \cdot d$

Unless specified otherwise in the technical specification (ETA or hEN) of cross laminated timber, minimum distances and spacing for screws in the edge surface of cross laminated timber members with a minimum thickness  $t = 10 \cdot d$  and a minimum penetration depth perpendicular to the edge surface of  $10 \cdot d$  may be taken as (see Annex B):

Spacing $a_1$ parallel to the CLT plane	$a_1 = 10 \cdot d$
Spacing $a_2$ perpendicular to the CLT plane	$a_2 = 4 \cdot d$
Distance $a_{3,c}$ from centre of the screw-part in timber to the unloaded end	$a_{3,c} = 7 \cdot d$
Distance $a_{3,t}$ from centre of the screw-part in timber to the loaded end	$a_{3,t} = 12 \cdot d$
Distance $a_{4,c}$ from centre of the screw-part in timber to the unloaded edge	$a_{4,c} = 3 \cdot d$
Distance $a_{4,t}$ from centre of the screw-part in timber to the loaded edge	$a_{4,t} = 6 \cdot d$

## **4 Attestation and verification of constancy of performance (AVCP)**

### **4.1 AVCP system**

According to the decision 97/176/EC of the European Commission<sup>1</sup>, as amended, the system(s) of assessment and verification of constancy of performance (see Annex V to Regulation (EU) No 305/2011) is 3.

## **5 Technical details necessary for the implementation of the AVCP system, as foreseen in the applicable EAD**

Technical details necessary for the implementation of the AVCP system are laid down in the control plan deposited at ETA-Danmark prior to CE marking.

Issued in Copenhagen on 2023-09-28 by



Thomas Bruun  
Managing Director, ETA-Danmark

**Annex A**  
**WBS EVO VFT**  
carbon steel<sup>1)</sup>

nominal size	Ø6,5	Ø8,0	Ø10,0	Ø11,3
d	6,5	8,0	10,0	11,3
di	4,5	5,2	5,9	8,0
dh	8,0	10,0	13,0	13,0
hh	5,5	6,5	6,5	6,5
p	3,0	3,8	4,6	5,6
dt	4,3	4,9	5,5	8,3
lt	4,0	5,0	6,0	12,0
dh2	11,5	14,5	17,8	18,0
hh2	5,7	7,4	8,7	7,0
dm	4,9	5,8	6,5	-
SW	-	SW13	-	SW17

L min	36	44	53	64
L max	195	480	600	1000

All dimensions in mm.<sup>2)</sup>

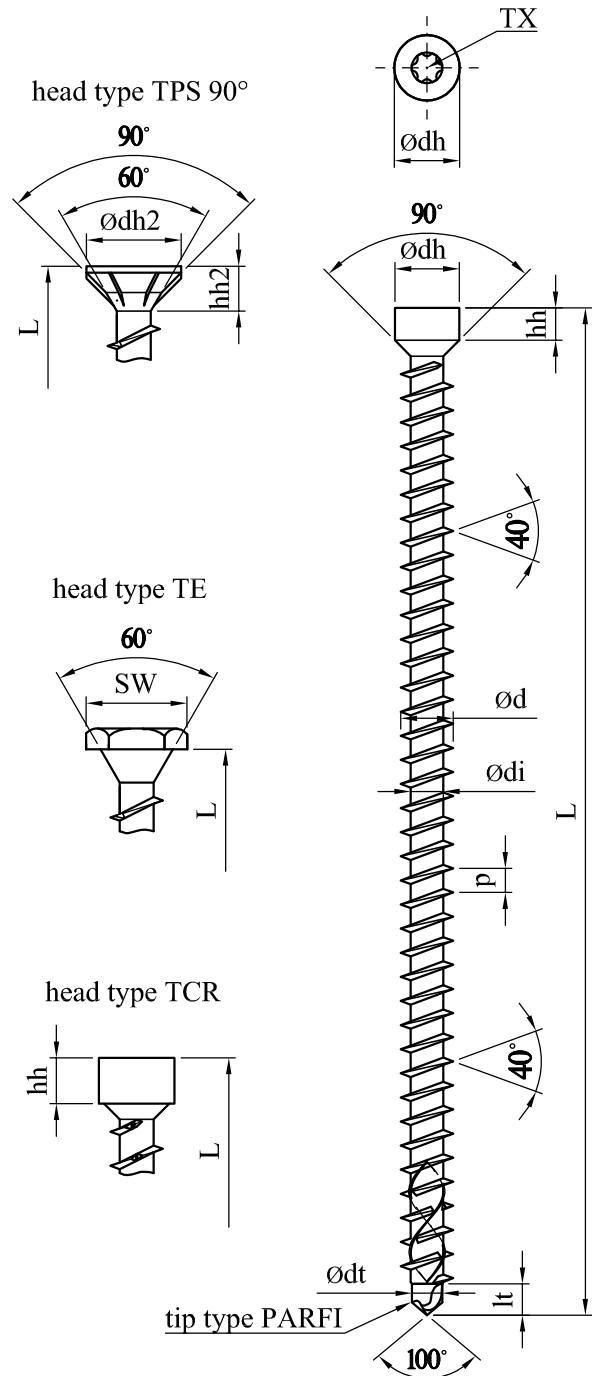

thread-free part  
acceptable for:  
L < 300 mm with ≈ 3 mm  
L ≥ 300 mm with ≈ 3x p

tip type PARFI

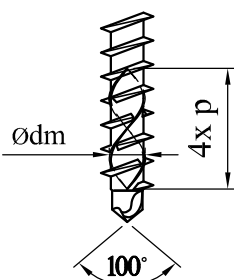

tip type PF

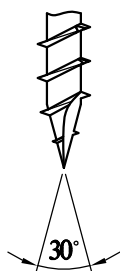

tip type PFI

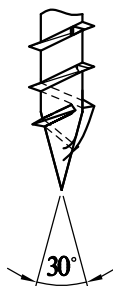

<sup>1)</sup> Material specification held on file by ETA Danmark.

<sup>2)</sup> Tolerances according to EAD 130118-XX-0603.

A head mark in shape of an ellipse instead of the "UFX" mark is allowed.

**WBS EVO VFT A4**  
stainless steel unhardened<sup>1</sup>

nominal size	Ø6,5	Ø8,0
d	6,5	8,0
di	4,5	5,2
dh	8,0	10,0
hh	5,5	6,5
p	3,0	3,8
dt	4,3	4,9
lt	4,0	5,0
dh2	12,0	14,5
hh2	5,7	7,4
dh3	-	22,0
dm	4,9	5,8
SW	-	SW13
SW2	SW8	SW10

L min	36	44
L max	195	400

All dimensions in mm.<sup>2)</sup>

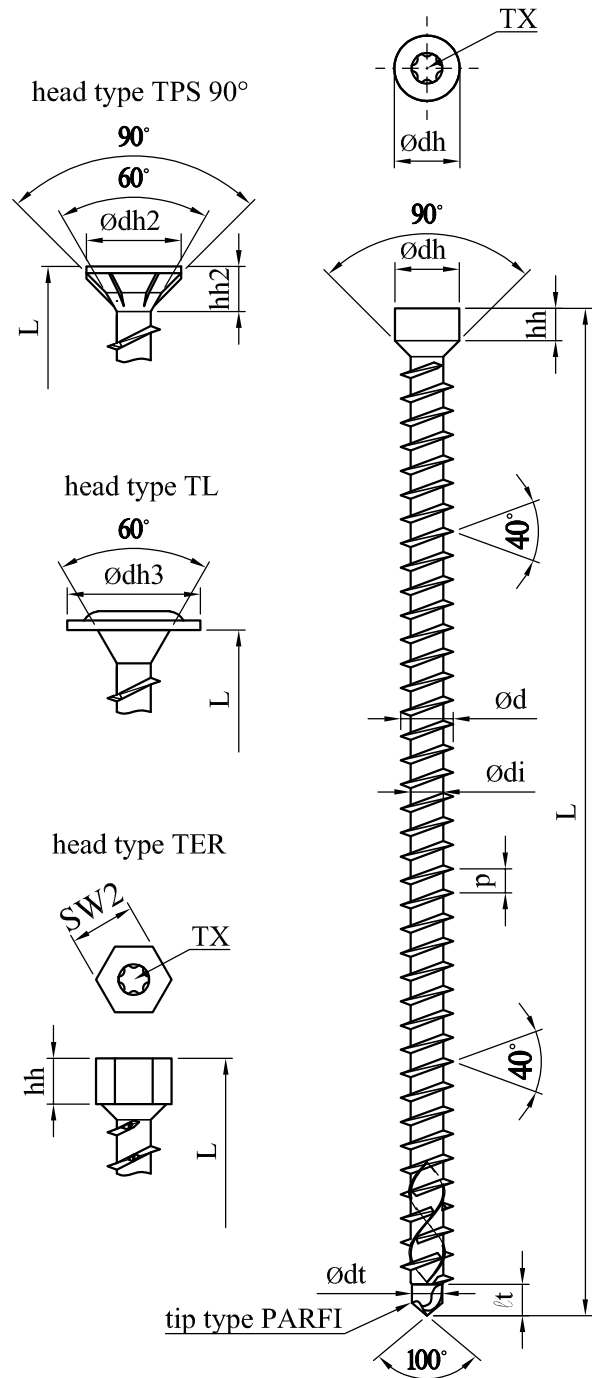

**thread-free part**  
acceptable for:  
L < 300 mm with ≈ 3 mm  
L ≥ 300 mm with ≈ 3x p

tip type PARFI

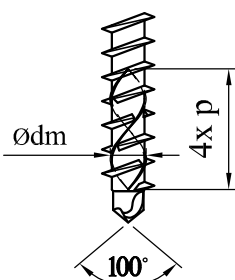

head type TE

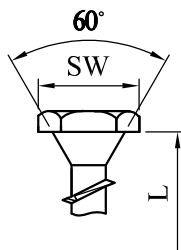

<sup>1)</sup> Material specification held on file by ETA Danmark.

<sup>2)</sup> Tolerances according to EAD 130118-XX-0603.

A head mark in shape of an ellipse instead of the "UFX" mark is allowed.

**WBS EVO VFT A4**  
stainless steel unhardened<sup>1</sup>

nominal size	Ø10,0
d	10,0
di	6,0
dh	13,0
hh	6,5
p	4,6
dh2	17,8
hh2	8,7
dh3	25,0
SW2	SW13

L min	49
L max	500

All dimensions in mm.<sup>2)</sup>

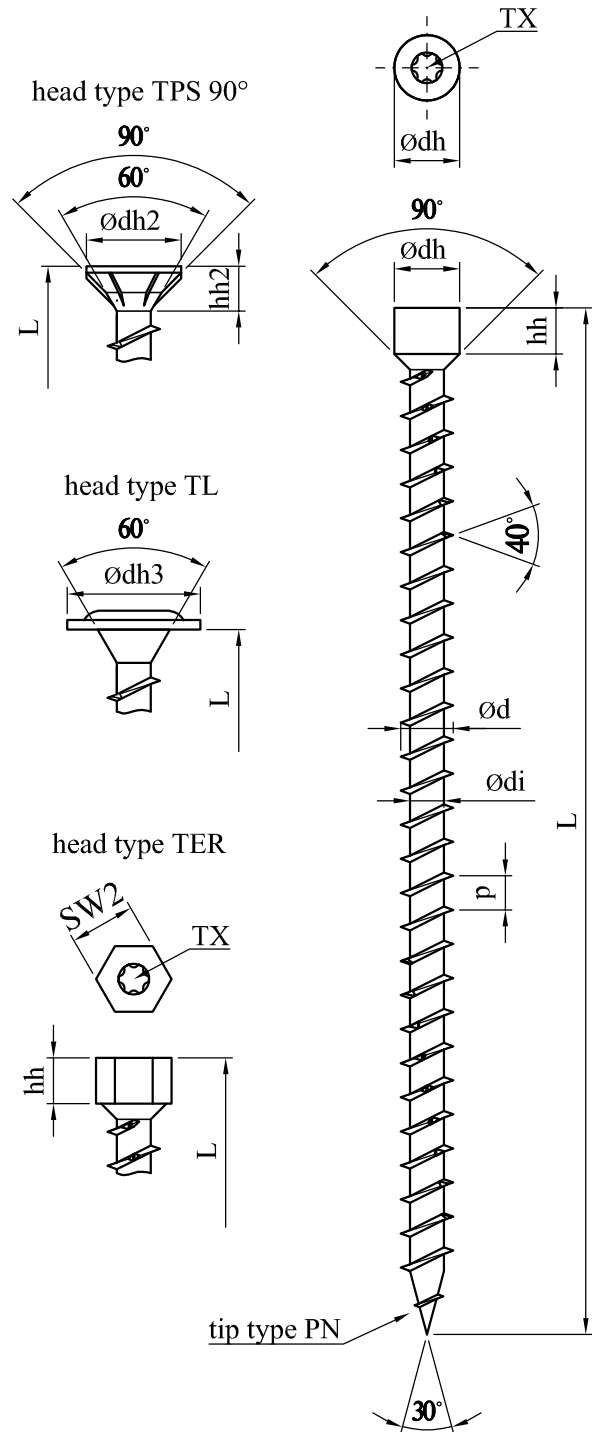

head type TE

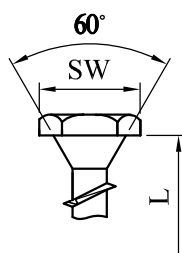

thread-free part

acceptable for:  
L < 300 mm with ≈ 3 mm  
L ≥ 300 mm with ≈ 3x p

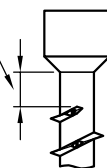

<sup>1)</sup> Material specification held on file by ETA Danmark.

<sup>2)</sup> Tolerances according to EAD 130118-XX-0603.

A head mark in shape of an ellipse instead of the "UFX" mark is allowed.

**WBS EVO VFT-DUO**  
carbon steel<sup>1</sup>

nominal size	Ø6,5	Ø8,0
d	6,5	8,0
di	4,5	5,2
dh	8,0	10,0
hh	5,5	6,5
p1	3,0	3,8
p2	2,8	3,7
ds	5,0	5,8
dt	4,3	4,9
lt	4,0	5,0

lg1 min	30	37
lg1 max	97	137

lg2 min	32	39
lg2 max	97	137

L min	87	102
L max	220	400

All dimensions in mm.<sup>2)</sup>

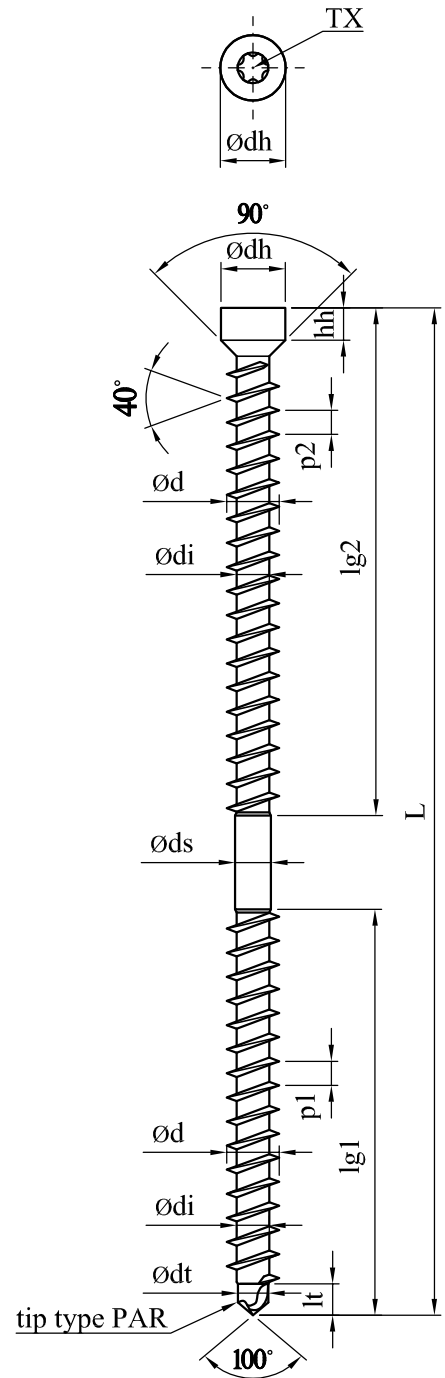

**thread-free part**

acceptable for:  
L < 300 mm with ≈ 3 mm  
L ≥ 300 mm with ≈ 3x p

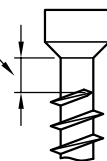

<sup>1)</sup> Material specification held on file by ETA Danmark.

<sup>2)</sup> Tolerances according to EAD 130118-XX-0603.

A head mark in shape of an ellipse instead of the "UFX" mark is allowed.

**WBS EVO TPS 90**  
 carbon steel<sup>1</sup>  
 stainless steel hardened<sup>1</sup>

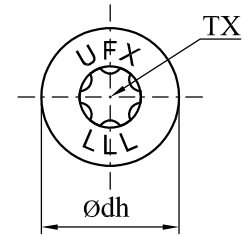

nominal size	Ø3,5	Ø4,0	Ø4,5	Ø5,0	Ø6,0	Ø8,0	Ø10,0	Ø12,0
d	3,5	4,0	4,5	5,0	6,0	8,0	10,0	12,0
di	2,1	2,5	2,7	3,3	4,0	5,3	6,3	7,1
dh	7,0	8,0	9,0	10,0	12,0	14,5	17,8	20,0
hh	3,5	4,0	4,4	4,8	5,7	7,0	8,7	9,3
p	2,25	2,5	2,8	3,1	4,9	5,6	6,6	6,6
ds	2,3	2,8	3,0	3,6	4,3	5,7	6,9	8,1
dm	2,7	2,9	3,4	3,9	4,8	6,5	7,9	9,6
dc	3,5	4,0	5,4	6,0	7,2	8,0	10,0	-
hhc	3,8	4,2	4,7	5,3	5,6	7,3	8,3	-
dh2	-	5,5	7,0	8,5	11,5	-	-	-
dm2	2,45	2,8	3,2	3,8	4,6	6,2	7,2	-
lg min	14	16	18	20	24	32	40	48
lg max	30	48	48	70	70	100	100	120
L min	18	20	23	25	30	39	49	57
L max	50	80	80	120	300	600	600	400

All dimensions in mm.<sup>2)</sup>

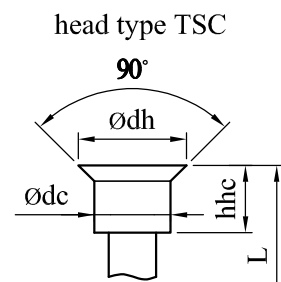
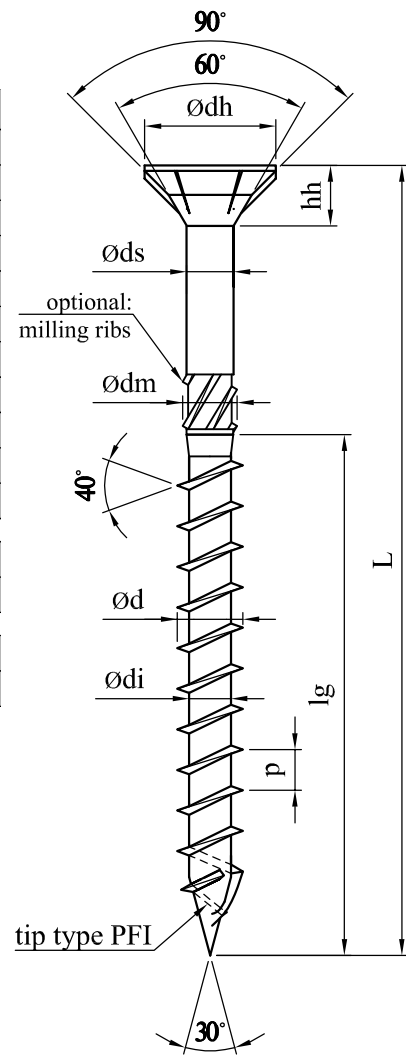

tip type PFA

tip type PN

tip type PF

tip type PFID

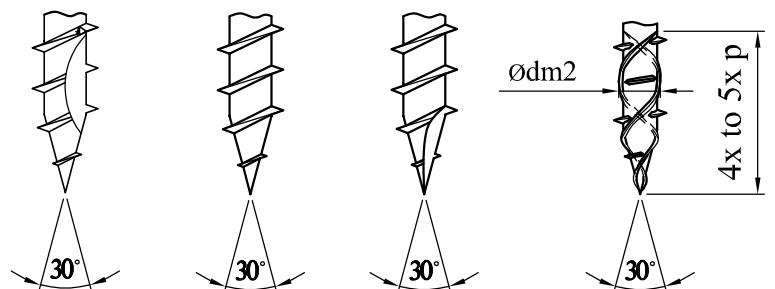

<sup>1)</sup> Material specification held on file by ETA Danmark.

<sup>2)</sup> Tolerances according to EAD 130118-XX-0603.

A head mark in shape of an ellipse instead of the "UFX" mark is allowed.

**WBS EVO TPS 60**  
 carbon steel<sup>1</sup>  
 stainless steel hardened<sup>1</sup>

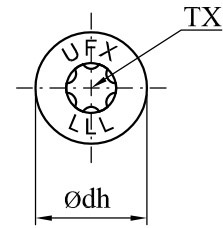

nominal size	Ø3,5	Ø4,0	Ø4,5	Ø5,0	Ø6,0	Ø8,0	Ø10,0
d	3,5	4,0	4,5	5,0	6,0	8,0	10,0
di	2,1	2,5	2,7	3,3	4,0	5,3	6,3
dh	5,0	6,0	7,0	7,5   9,5*	11,0	13,0	16,5
hh	1,9	3,6	4,3	4,8	5,8	6,3	8,2
p	2,25	2,5	2,8	3,1	4,9	5,6	6,6
ds	2,3	2,8	3,0	3,6	4,3	5,7	6,9
dm	2,7	2,9	3,4	3,9	4,8	6,5	7,9
dt	2,0	2,3	2,5	2,9	3,4	5,3	6,3
lt	3,4	3,9	4,4	4,9	4,9	5,1	6,1
dc	3,5	4,0	5,4	6,0	7,2	8,0	10,0
hhc	3,8	4,2	4,7	5,3	5,6	7,3	8,3
dh2	-	5,5	7,0	8,5	11,5	-	-
dm2	2,45	2,8	3,2	3,8	4,6	6,2	7,2

lg min	14	16	18	20	24	32	40
lg max	30	48	48	70	70	100	100

L min	18	20	23	25	30	39	48
L max	50	80	80	120	300	600	600

All dimensions in mm.<sup>2)</sup>  
 \*dh= 7,5 mm standard version  
 dh= 9,5 mm special version

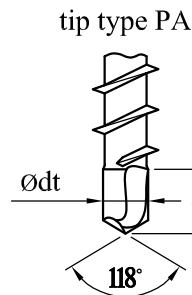
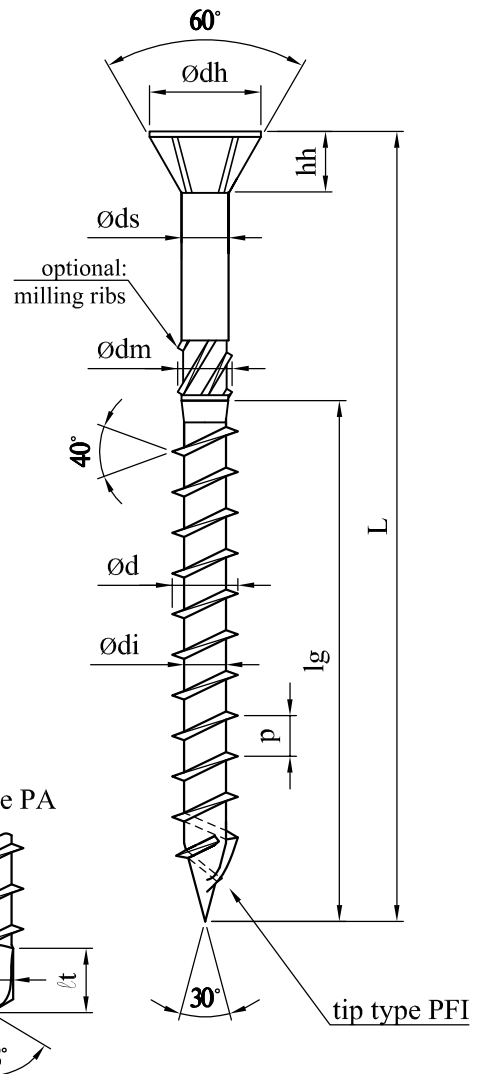

tip type PFI

tip type PFA

tip type PN

tip type PF

tip type PFID

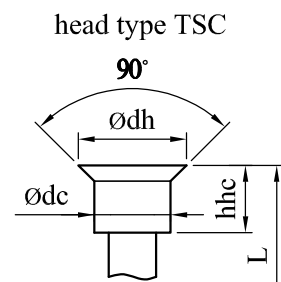
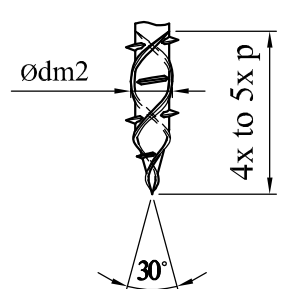
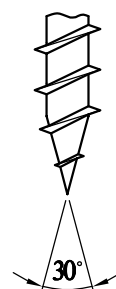
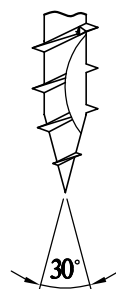

<sup>1)</sup> Material specification held on file by ETA Danmark.

<sup>2)</sup> Tolerances according to EAD 130118-XX-0603.

A head mark in shape of an ellipse instead of the "UFX" mark is allowed.

**WBS EVO TL**  
 carbon steel<sup>1</sup>  
 stainless steel hardened<sup>1</sup>

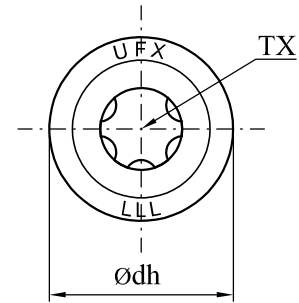

nominal size	Ø3,5	Ø4,0	Ø4,5	Ø5,0	Ø6,0	Ø8,0	Ø10,0
d	3,5	4,0	4,5	5,0	6,0	8,0	10,0
di	2,1	2,5	2,7	3,3	4,0	5,3	6,3
dh	8,0	10,0	11,0	12,0	14,0	22,0	25,0
dc	4,3	4,8	5,5	6,0	7,0	10,0	12,0
p	2,25	2,5	2,8	3,1	4,9	5,6	6,6
ds	2,3	2,8	3,0	3,6	4,3	5,7	6,9
dm	2,7	2,9	3,4	3,9	4,8	6,5	7,9
dm2	2,45	2,8	3,2	3,8	4,6	6,2	7,2

lg min	14	16	18	20	24	32	40
lg max	30	48	48	70	70	100	100

L min	15	17	19	21	25	33	41
L max	50	80	80	120	300	600	600

All dimensions in mm.<sup>2)</sup>

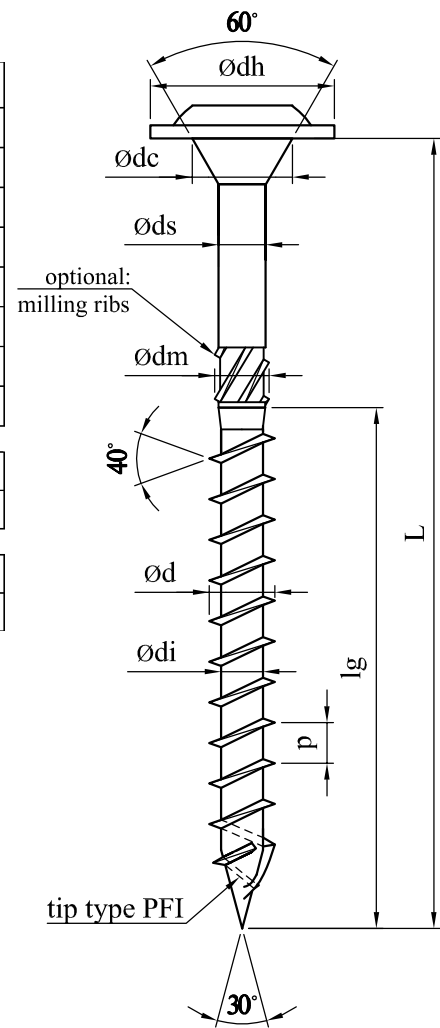

tip type PFA

tip type PN

tip type PF

tip type PFID

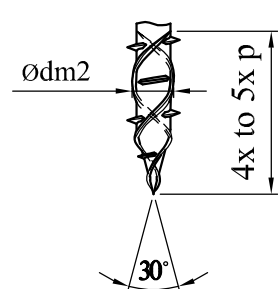
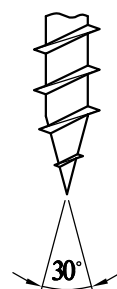
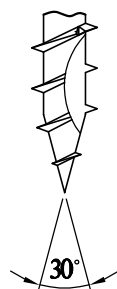

<sup>1)</sup> Material specification held on file by ETA Denmark.

A head mark in shape of an ellipse instead of the "UFX" mark is allowed.

<sup>2)</sup> Tolerances according to EAD 130118-XX-0603.

**WBS EVO TLR**  
 carbon steel<sup>1</sup>  
 stainless steel hardened<sup>1</sup>

nominal size	Ø8,0
d	8,0
di	5,3
dh	18,0
dc	8,0
p	5,6
ds	5,8
dm	6,7
dm2	6,2

lg min	32
lg max	100

L min	33
L max	600

All dimensions in mm.<sup>2)</sup>

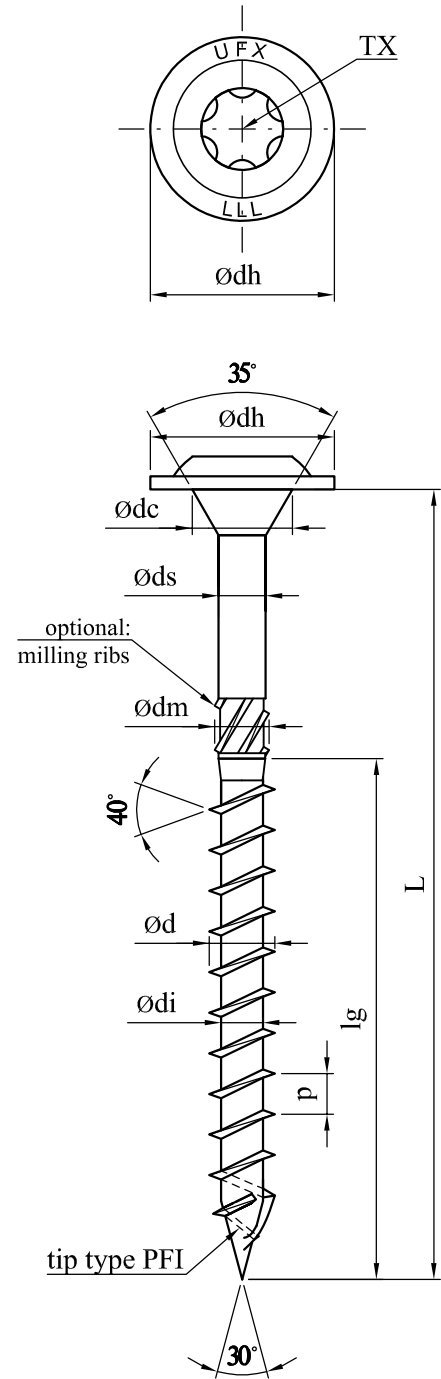

tip type PFA

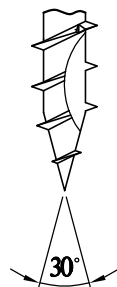

tip type PN

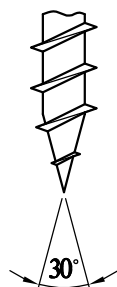

tip type PF



tip type PFID

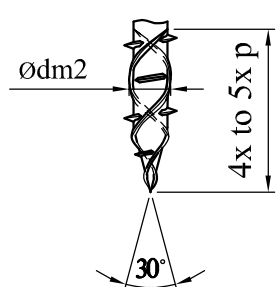

<sup>1)</sup> Material specification held on file by ETA Danmark.

A head mark in shape of an ellipse instead of the "UFX" mark is allowed.

<sup>2)</sup> Tolerances according to EAD 130118-XX-0603.

**WBS EVO TPS A2**  
stainless steel unhardened<sup>1</sup>

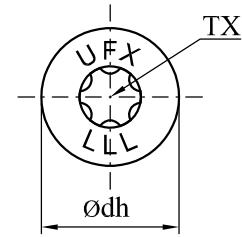

nominal size	Ø8,0
d	8,0
di	5,3
dh	14,5
hh	7,0
p	5,6
ds	5,7
dm	6,5
dc	8,0
hhc	7,3
dh2	16,0

lg min	32
lg max	80

L min	39
L max	140

All dimensions in mm.<sup>2)</sup>

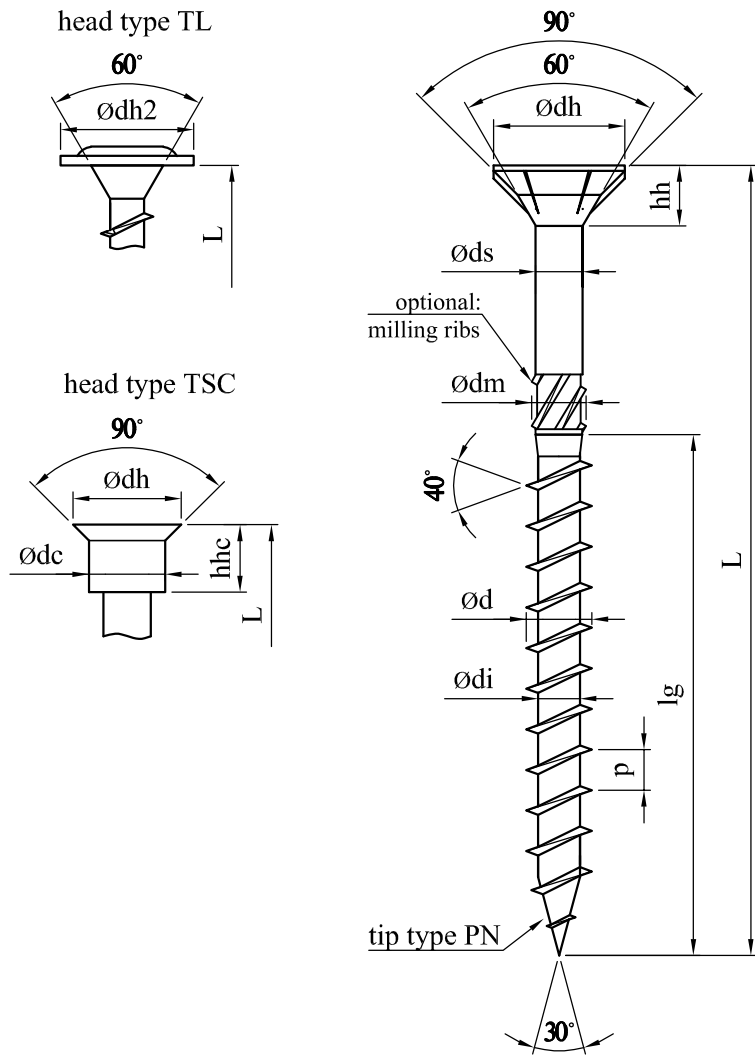

<sup>1)</sup> Material specification held on file by ETA Danmark.

<sup>2)</sup> Tolerances according to EAD 130118-XX-0603.

A head mark in shape of an ellipse instead of the "UFX" mark is allowed.

**WBS EVO VF-DUO**  
 carbon steel<sup>1</sup>  
 stainless steel hardened<sup>1</sup>

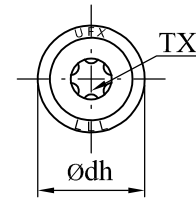

nominal size	Ø8,0
d	8,0
di	5,3
dh	16,0
dc	8,0
p	5,6
ds	5,8
dm	6,5
dh2	14,5
hh2	7,4
dh3	10,0
hh3	6,5
dh4	18,3
hh4	7,3
dm2	6,20

lg1 min	32
lg1 max	100

lg2 min	32
lg2 max	60

L min	94
L max	472

All dimensions in mm.<sup>2)</sup>

head type TPS 90°

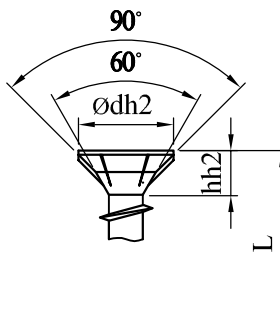

head type TCR

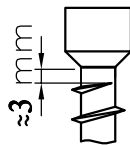
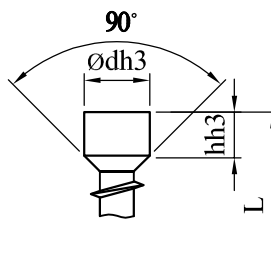

head type TSC

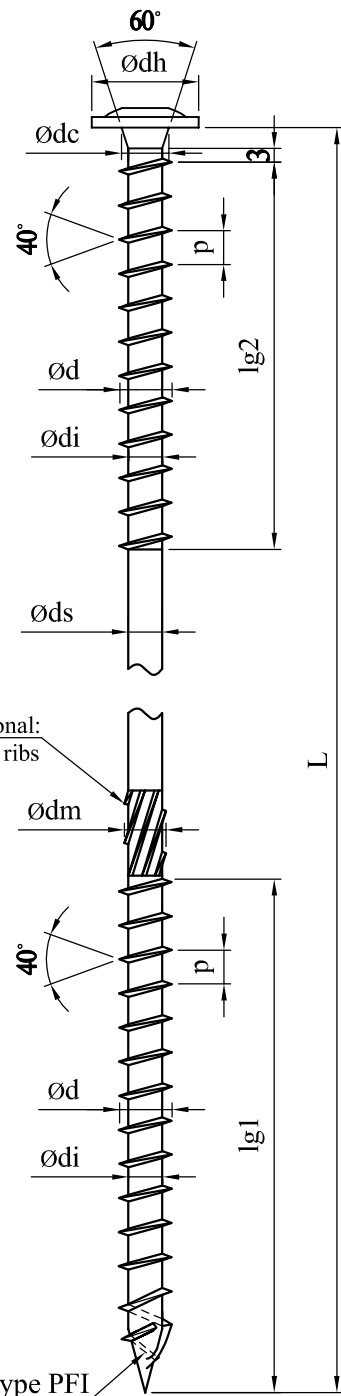
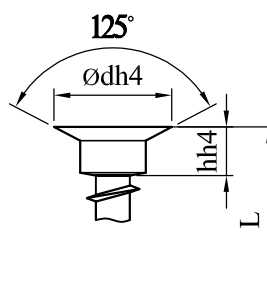

tip type PN

tip type PF

tip type PFID

tip type PFA

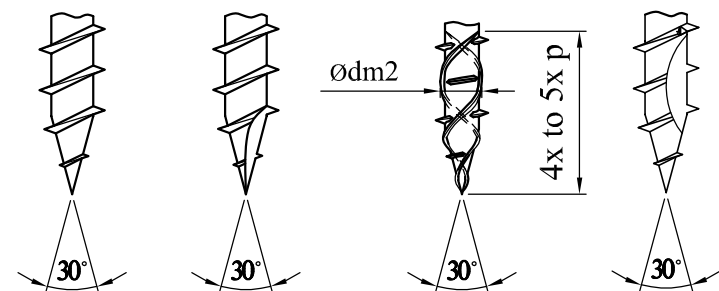

<sup>1)</sup> Material specification held on file by ETA Danmark.

<sup>2)</sup> Tolerances according to EAD 130118-XX-0603.

A head mark in shape of an ellipse instead of the "UFX" mark is allowed.

**WBS EVO TC-TX**  
carbon steel<sup>1</sup>

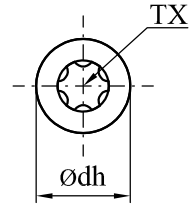

nominal size	Ø5,0
d	5,0
di	3,2
dh	7,2
hh	3,0
p	2,2
dc	4,8

lg min	20
lg max	70

L min	29
L max	80

All dimensions in mm.<sup>2)</sup>

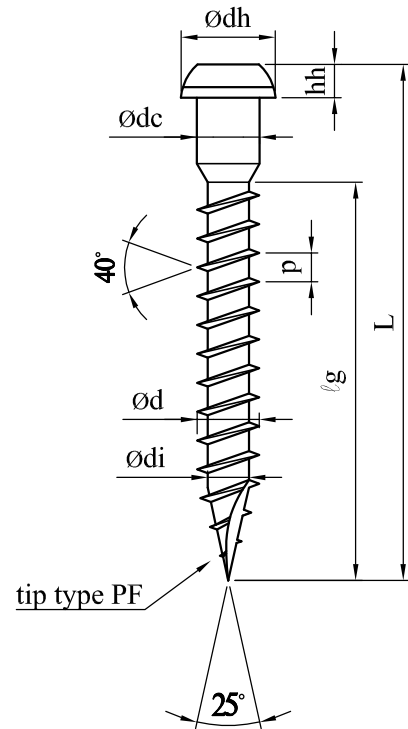

tip type PFA

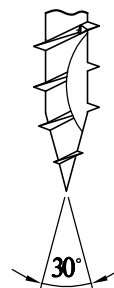

tip type PN

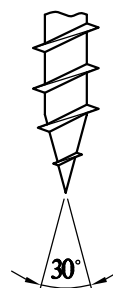

tip type PFI

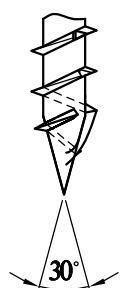

<sup>1)</sup> Material specification held on file by ETA Danmark.  
A head mark in shape of an ellipse instead of the "UFX" mark is allowed.

<sup>2)</sup> Tolerances according to EAD 130118-XX-0603.

**WBS EVO VAB-TX**  
carbon steel<sup>1</sup>

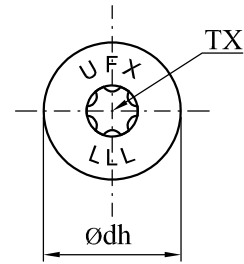

nominal size	Ø4,0	Ø4,5	Ø5,0	Ø6,0	Ø8,0	Ø10,0
d	4,0	4,5	5,0	6,0	8,0	10,0
di	2,5	2,7	3,3	4,0	5,3	6,3
dh	8,5	9,5	10,5	13,0	18,0	22,0
hh	1,7	1,7	2,3	2,4	2,6	3,1
p	2,5	2,8	3,1	4,9	5,6	6,6
ds	2,8	3,0	3,6	4,4	5,8	7,1
dm	2,9	3,4	3,9	4,9	6,7	7,9
dm2	2,8	3,2	3,8	4,6	6,2	7,2

lg min	16	18	20	24	32	40
lg max	48	48	70	70	100	100

L min	18	20	22	26	35	43
L max	80	80	120	300	600	600

All dimensions in mm.<sup>2)</sup>

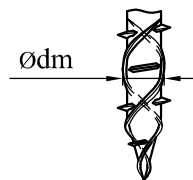
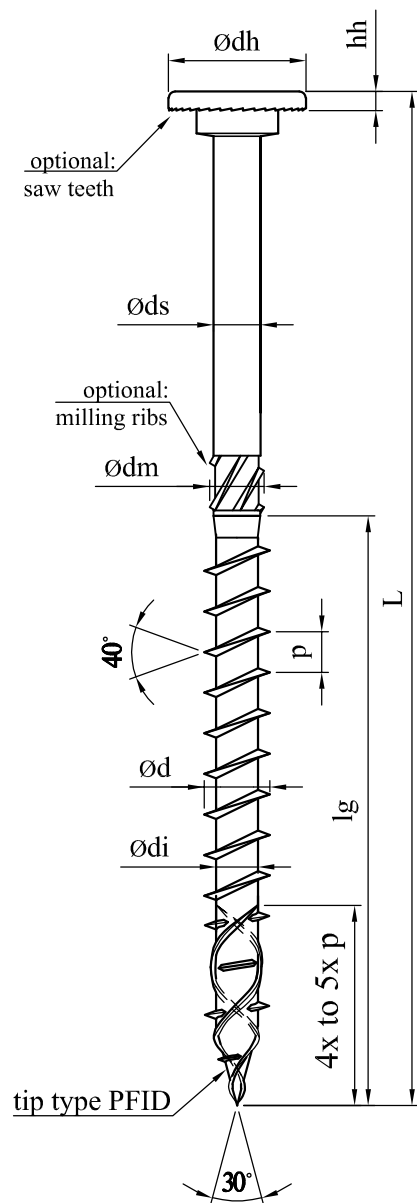

<sup>1)</sup> Material specification held on file by ETA Danmark.

<sup>2)</sup> Tolerances according to EAD 130118-XX-0603.

A head mark in shape of an ellipse instead of the "UFX" mark is allowed.

**WBS EVO VTG**  
carbon steel<sup>1</sup>

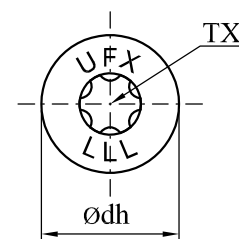

nominal size	Ø8,0
d	8,0
di	6,1
dh	15,0
hh	6,7
p	3,7
ds	6,4
dm	6,9
$l_m$	10,5
dm2	6,9

lg min	32
lg max	80

L min	39
L max	240

All dimensions in mm.<sup>2)</sup>

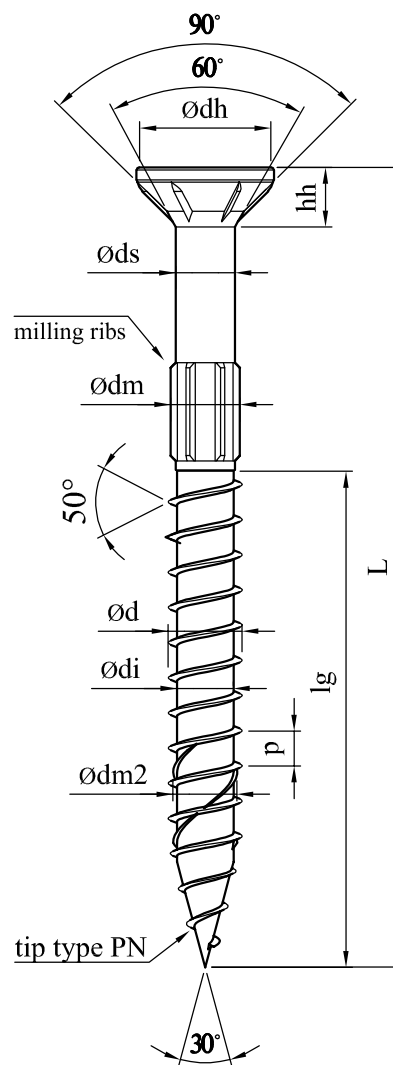

<sup>1)</sup> Material specification held on file by ETA Danmark.

<sup>2)</sup> Tolerances according to EAD 130118-XX-0603.

A head mark in shape of an ellipse instead of the "UFX" mark is allowed.

**WBS EVO VVG**  
carbon steel<sup>1</sup>

nominal size	Ø8,0
d	8,0
di	6,1
dh	10,0
hh	6,5
p	3,8
dm	6,9

L min	39
L max	400

All dimensions in mm.<sup>2)</sup>

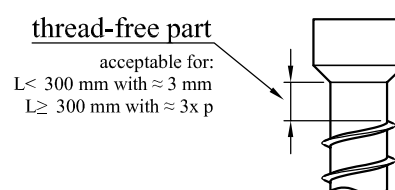
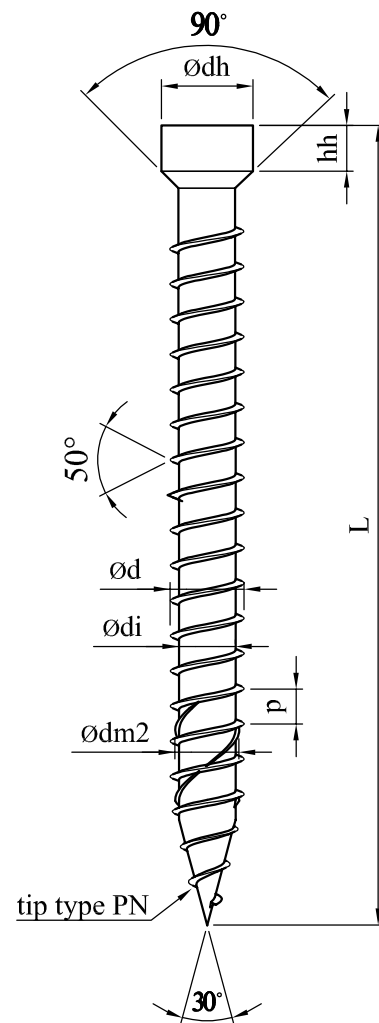
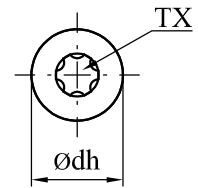

<sup>1)</sup> Material specification held on file by ETA Danmark.

<sup>2)</sup> Tolerances according to EAD 130118-XX-0603.

A head mark in shape of an ellipse instead of the "UFX" mark is allowed.

**WBS EVO RONDELLA**  
carbon steel<sup>1</sup>

Washer for head type TPS 90°

nominal size	Ø5,0	Ø6,0	Ø8,0	Ø10,0	
d	min	5,35	7,70	8,70	11,60
	max	5,85	8,30	9,30	12,40
da	min	15,50	19,50	24,50	31,50
	max	16,50	20,50	25,50	32,50
dh	min	9,90	13,60	16,00	22,00
	max	10,70	14,40	17,00	23,00
h	min	2,50	4,30	5,30	6,30
	max	2,90	4,70	5,70	6,70

All dimensions in mm.

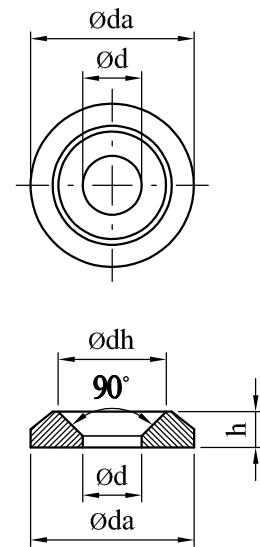

<sup>1</sup>Material specification held on file by ETA Danmark.

## Annex B Minimum distances and spacing

Axially loaded screws  
Single configuration

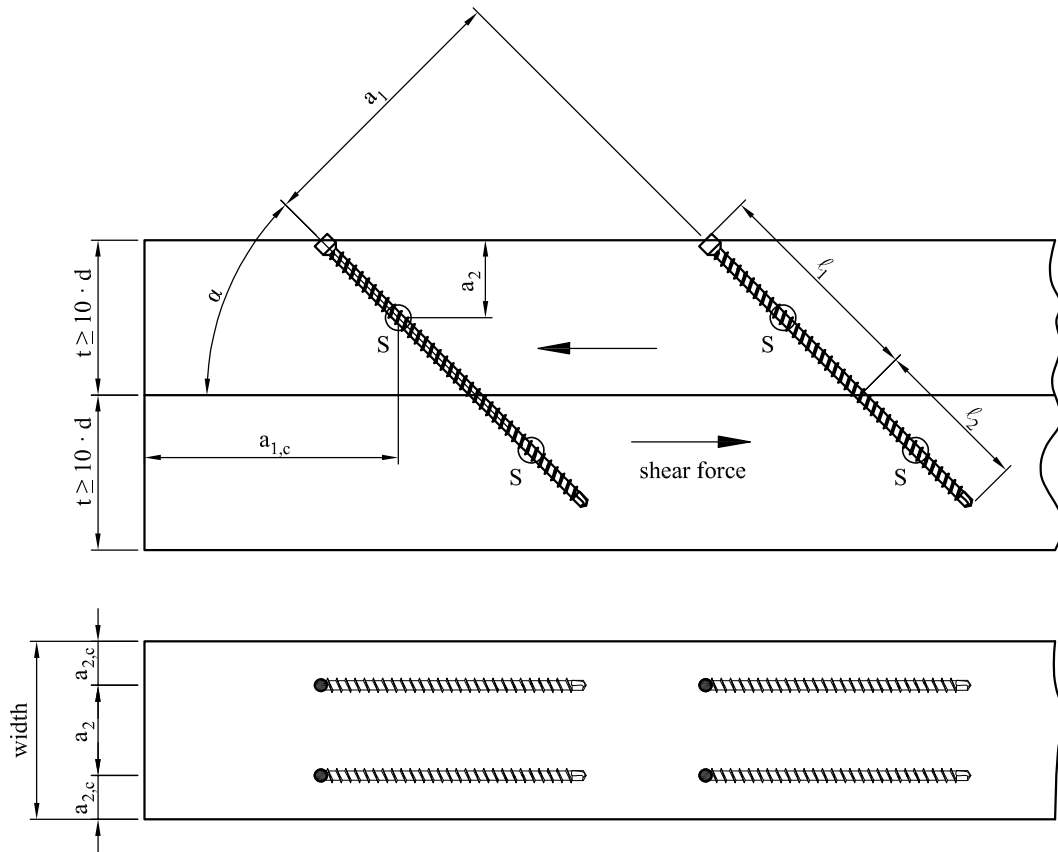

S = centroid of the part of the screw in the timber

Minimum distances and spacings for exclusively axially loaded screws in non-predrilled holes.  
Minimum timber thickness  $t = 10 \cdot d$ , minimum timber width  $w = \max \{8 \cdot d; 60 \text{ mm}\}$ .  
 $a_1 \geq 5 \cdot d$      $a_2 \geq 5 \cdot d$      $a_{1,c} \geq 10 \cdot d$      $a_{2,c} \geq 4 \cdot d$

Minimum distances and spacings for exclusively axially loaded screws in predrilled holes or for screws with tip type PARFI in non-predrilled holes. Minimum timber thickness  $t = 10 \cdot d$ , minimum timber width  $w = \max \{8 \cdot d; 60 \text{ mm}\}$ .  
 $a_1 \geq 5 \cdot d$      $a_2 \geq 5 \cdot d$      $a_{1,c} \geq 5 \cdot d$      $a_{2,c} \geq 3 \cdot d$

Spacing  $a_2$  may be reduced from  $5 \cdot d$  to  $2,5 \cdot d$ , if the condition  $a_1 \cdot a_2 \geq 25 \cdot d^2$  is fulfilled.

For a crossed screw couple the minimum spacing between the crossing screws is  $1,5 \cdot d$ .

Minimum distances and spacings, see also 3.12  
 $0^\circ \leq \alpha \leq 90^\circ$  for all tip types, see also 3.9

Axially loaded screws  
Crosswise configuration

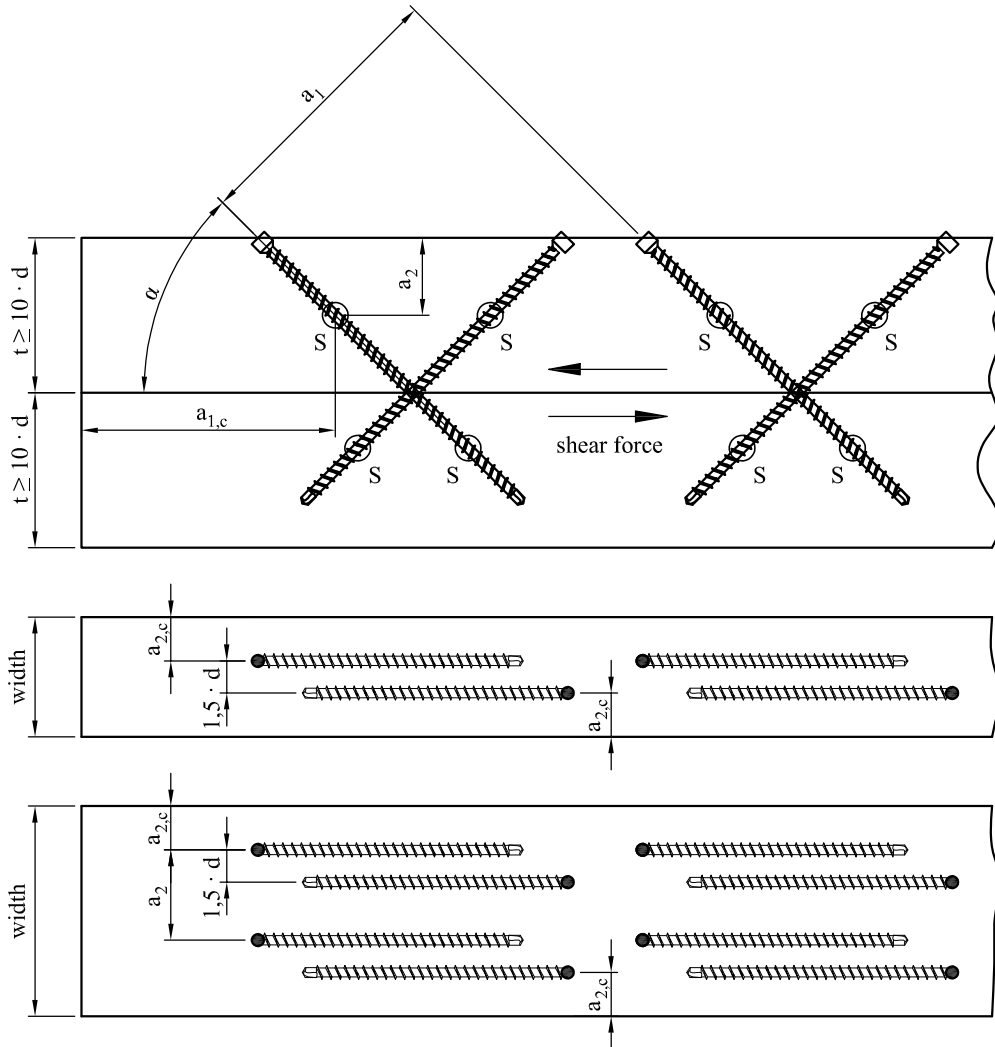

S = centroid of the part of the screw in the timber

Minimum distances and spacings for exclusively axially loaded screws in non-predrilled holes.

Minimum timber thickness  $t = 10 \cdot d$ , minimum timber width  $w = \max \{8 \cdot d; 60 \text{ mm}\}$ .

$$a_1 \geq 5 \cdot d \quad a_2 \geq 5 \cdot d \quad a_{1,c} \geq 10 \cdot d \quad a_{2,c} \geq 4 \cdot d$$

Minimum distances and spacings for exclusively axially loaded screws in predrilled holes or for screws with tip type PARFI in non-predrilled holes. Minimum timber thickness  $t = 10 \cdot d$ , minimum timber width  $w = \max \{8 \cdot d; 60 \text{ mm}\}$ .

$$a_1 \geq 5 \cdot d \quad a_2 \geq 5 \cdot d \quad a_{1,c} \geq 5 \cdot d \quad a_{2,c} \geq 3 \cdot d$$

Spacing  $a_2$  may be reduced from  $5 \cdot d$  to  $2,5 \cdot d$ , if the condition  $a_1 \cdot a_2 \geq 25 \cdot d^2$  is fulfilled.

For a crossed screw couple the minimum spacing between the crossing screws is  $1,5 \cdot d$ .

Minimum distances and spacings, see also 3.12

$0^\circ \leq \alpha \leq 90^\circ$  for all tip types, see also 3.9

Axially or laterally loaded screws in the plane or edge surface of cross laminated timber

Figure 1: Definition of spacing, end and edge distances in the plane surface (wide face) unless otherwise specified in the technical specification (ETA or hEN) for the cross laminated timber:

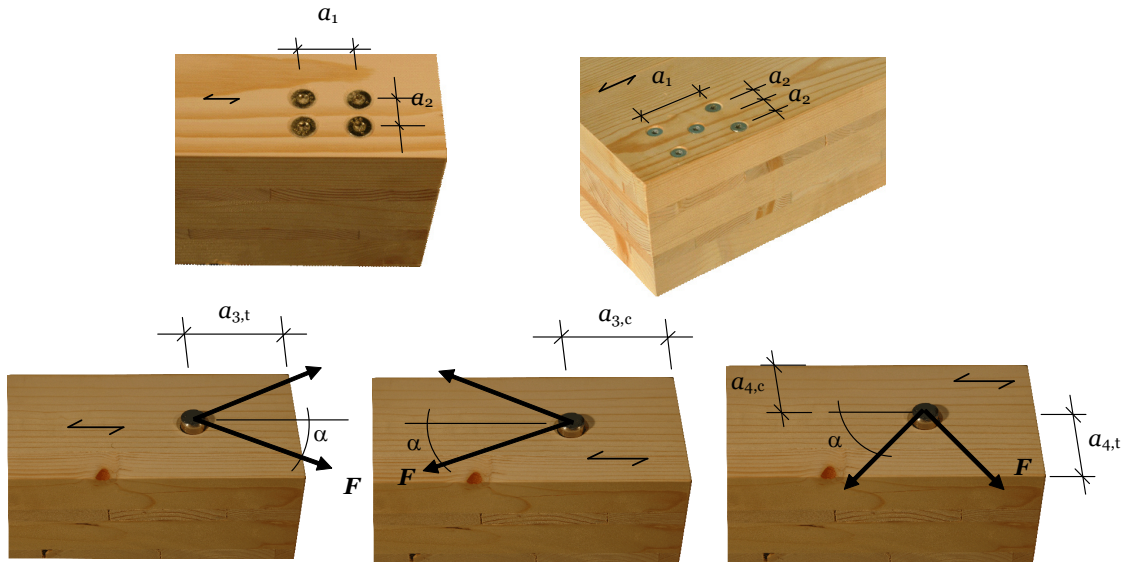
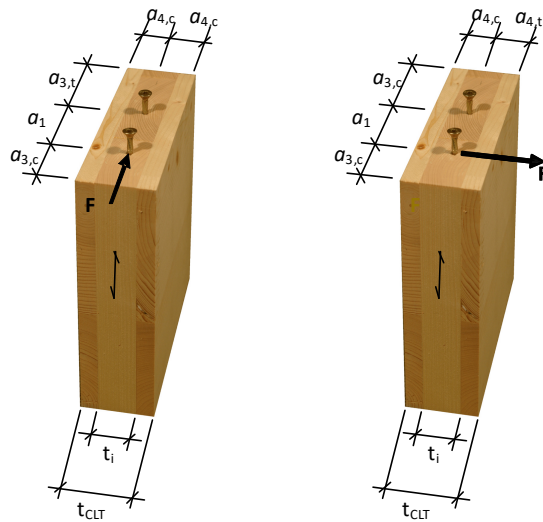

Figure 2: Definition of spacing, end and edge distances in the edge surface unless otherwise specified in the technical specification (ETA or hEN) for the cross laminated timber:



Minimum distances and spacing for screws in the plane surface (wide surface) or edge surface of cross laminated timber

	$a_1$	$a_{3,t}$	$a_{3,c}$	$a_2$	$a_{4,t}$	$a_{4,c}$
Plane surface (wide face), see figure 1	$4 \cdot d$	$6 \cdot d$	$6 \cdot d$	$2,5 \cdot d$	$6 \cdot d$	$2,5 \cdot d$
Edge surface, see figure 2	$10 \cdot d$	$12 \cdot d$	$7 \cdot d$	$4 \cdot d$	$6 \cdot d$	$3 \cdot d$

## Annex C Compression reinforcement

„WBS EVO VFT“ screws with a full thread may be used for reinforcement of timber members with compression stresses at an angle  $\alpha$  to the grain of  $45^\circ \leq \alpha \leq 90^\circ$ . The compression force must be evenly distributed over all screws.

The characteristic load-carrying capacity for a contact area with screws with a full thread at an angle  $\alpha$  to the grain of  $45^\circ < \alpha < 90^\circ$  shall be calculated from:

$$F_{90,Rd} = \min \left\{ \begin{array}{l} k_{c,90} \cdot B \cdot \ell_{ef,1} \cdot f_{c,90,d} + n \cdot \min (F_{ax,Rd}; F_{ki,Rd}) \\ B \cdot \ell_{ef,2} \cdot f_{c,90,d} \end{array} \right\}$$

Where

- $F_{90,Rd}$  design load-carrying capacity of reinforced contact area [N]
- $k_{c,90}$  factor for compression perpendicular to the grain according to EN 1995-1-1
- $B$  bearing width [mm]
- $\ell_{ef,1}$  effective length of contact area according to EN 1995-1-1 [mm]
- $f_{c,90,d}$  design compressive strength perpendicular to the grain [N/mm<sup>2</sup>]
- $n$  number of reinforcement screws,  $n = n_0 \cdot n_{90}$
- $n_0$  number of reinforcement screws arranged in a row parallel to the grain
- $n_{90}$  number of reinforcement screws arranged in a row perpendicular to the grain
- $F_{ax,Rd}$  design axial withdrawal capacity [N]
- $F_{ki,Rd}$  design buckling capacity [N]
- $\ell_{ef,2}$  effective distribution length in the plane of the screw tips [mm]
- $\ell_{ef,2} = \ell_{ef} + (n - 1) \cdot a + \min(\ell_{ef}; a_{1,c})$  for end bearings [mm]
- $\ell_{ef,2} = 2 \cdot \ell_{ef} + (n_0 - 1) \cdot a_1$  for centre-bearings [mm]
- $a_1$  spacing parallel to the grain [mm]
- $a_{1,c}$  end distance [mm]

Reinforcing screws for wood-based panels are not covered by this European Technical Assessment.

Reinforced end bearing

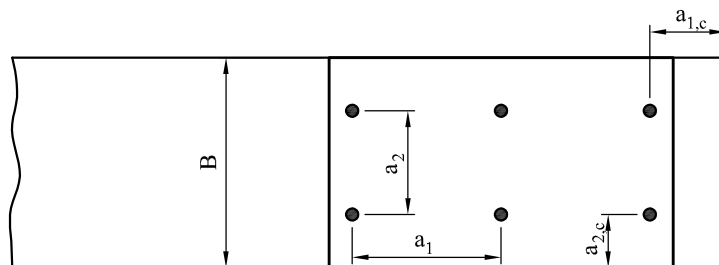
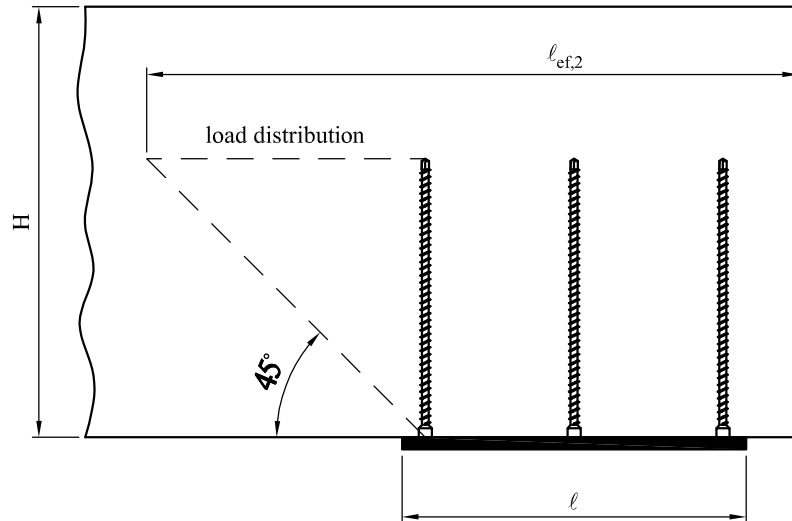

- H component height [mm]  
 B bearing width [mm]  
 $l_{ef}$  point side penetration length [mm]  
 $l_{ef,2}$  effective distribution length in the plane of the screw tips [mm]  
 $= l_{ef} + (n_0 - 1) \cdot a_1 + \min(l_{ef}; a_{1,c})$  for end bearings

Reinforced centre-bearing

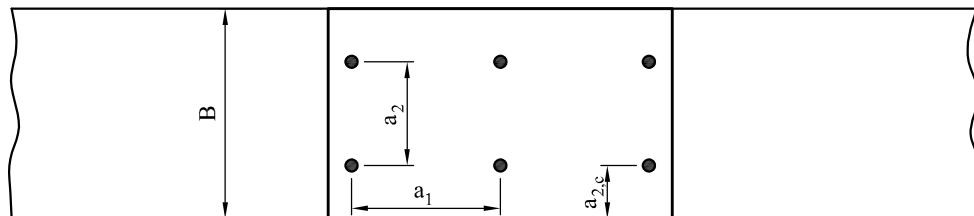
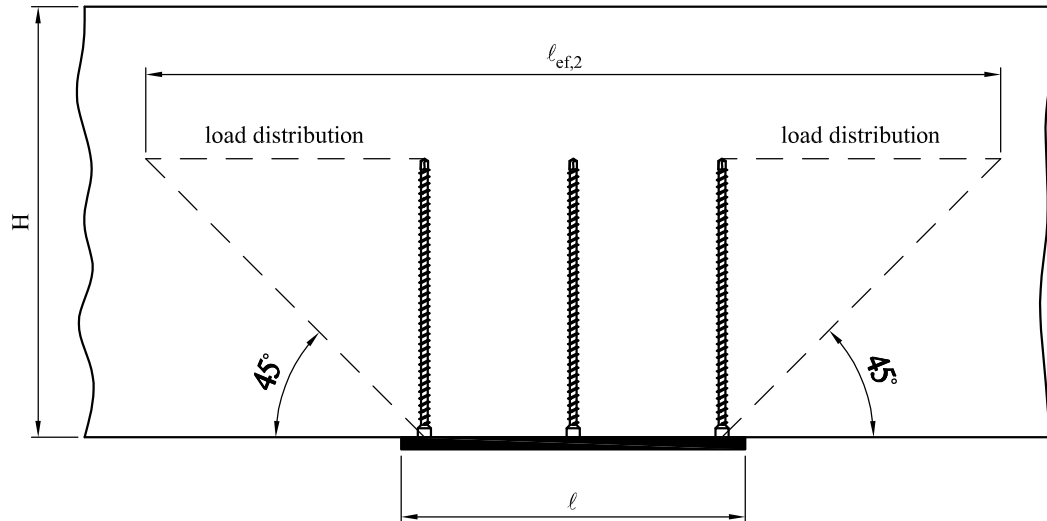

- H component height [mm]
- B bearing width [mm]
- $l_{\text{ef}}$  point side penetration length [mm]
- $l_{\text{ef},2}$  effective distribution length in the plane of the screw tips [mm]  
 $= 2 \cdot l_{\text{ef}} + (n_0 - 1) \cdot a_1$  for centre-bearings

## Annex D Tensile reinforcement perpendicular to grain

Timber member loaded by a connection force perpendicular to the grain

„WBS EVO VFT“ screws with a full thread may be used for reinforcement of timber members with tensile stresses perpendicular to the grain. The tensile force must be evenly distributed over all screws.

Unless specified otherwise in national provisions that apply at the installation site, the axial capacity of a reinforcement of a timber member loaded by a connection force perpendicular to the grain shall fulfil the following condition:

$$\frac{[1 - 3 \cdot \alpha^2 + 2 \cdot \alpha^3] \cdot F_{90,d}}{F_{ax,Rd}} \leq 1$$

Where

$F_{90,d}$  design value of the force component perpendicular to the grain [N]

$\alpha = a/h$  [mm]

$h$  member depth [mm]

$F_{ax,Rd}$  minimum of the design values of the withdrawal capacity and the tensile capacity of the reinforcing screws or threaded rods where  $\ell_{ef}$  is the smaller value of the penetration depth below or above the potential crack [N]

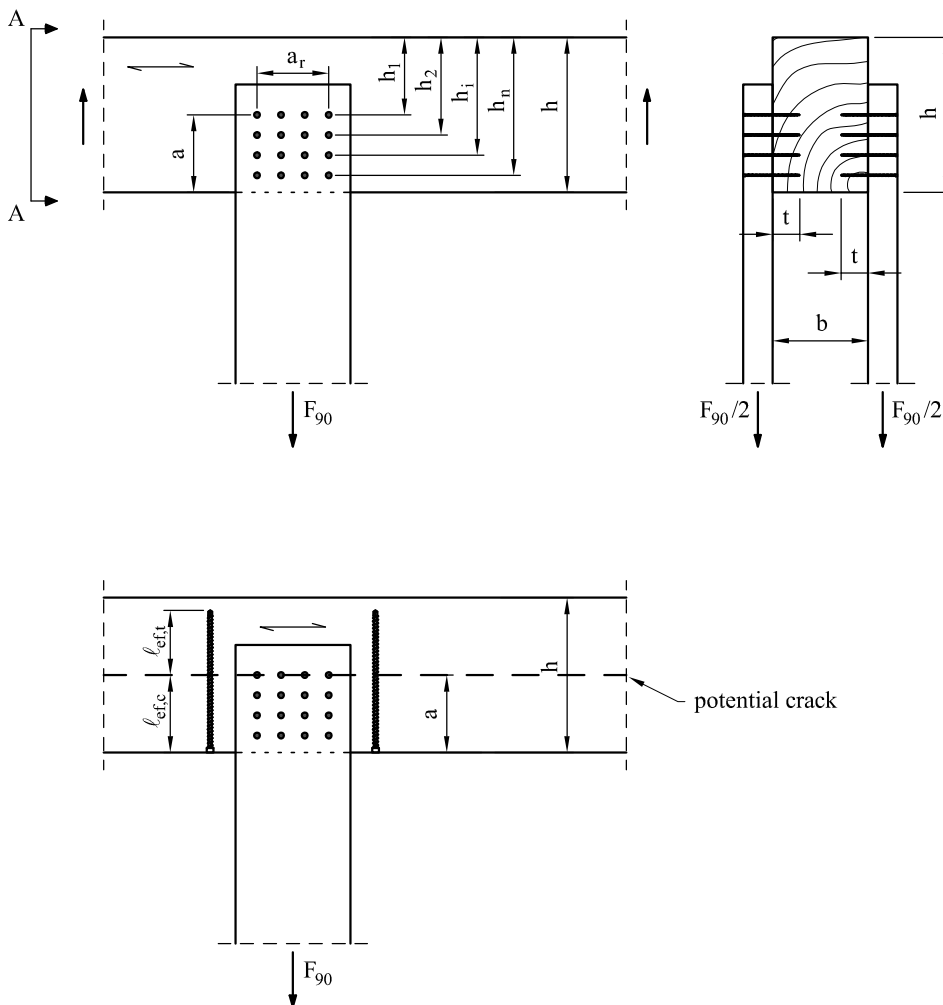

### Notched beam support

Unless specified otherwise in national provisions that apply at the installation site, the axial capacity of a reinforcement of a notched beam support shall fulfil the following condition:

$$\frac{1,3 \cdot V_d \cdot [3 \cdot (1 - \alpha)^2 - 2 \cdot (1 - \alpha)^3]}{F_{ax,Rd}} \leq 1$$

Where

$V_d$  design value of the shear force [N]

$\alpha = h_{ef}/h$  [mm]

$h$  member depth [mm]

$F_{ax,Rd}$  minimum of the design values of the withdrawal capacity and the tensile capacity of the reinforcing screws or threaded rods where  $\ell_{ef}$  is the smaller value of the penetration depth below or above the potential crack [N]

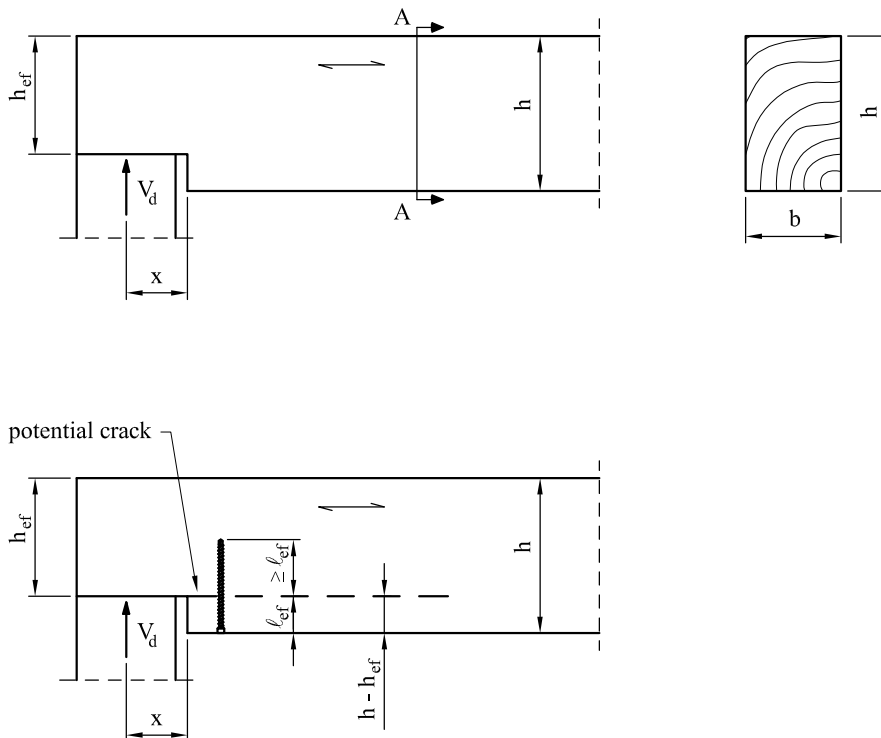

Beam hole

Unless specified otherwise in national provisions that apply at the installation site, the axial capacity of a reinforcement of a hole in a beam shall fulfil the following condition:

$$\frac{F_{t,V,d} + F_{t,M,d}}{F_{ax,Rd}} \leq 1$$

Where

$F_{t,V,d}$  design value of the force perpendicular to the grain due to shear force:

$$F_{t,V,d} = \frac{V_d \cdot h_d}{4 \cdot h} \cdot \left[ 3 - \frac{h_d^2}{h^2} \right] \quad [\text{N}]$$

$V_d$  design value of the shear force [N]

$h$  member depth [mm]

$h_d$  hole depth for rectangular holes [mm]

$h_d$  70 % of hole diameter for circular holes [mm]

$F_{t,M,d}$  design value of the force perpendicular to the grain due to bending moment:

$$F_{t,M,d} = 0,008 \cdot \frac{M_d}{h_r} \quad [\text{N}]$$

$M_d$  design value of the member bending moment at the hole end [Nmm]

$h_r = \min(h_{ro}; h_{ru})$  for rectangular holes [mm]

$h_r = \min(h_{ro}; h_{ru}) + 0,15 \cdot h_d$  for circular holes [mm]

$F_{ax,Rd}$  minimum of the design values of the withdrawal capacity and the tensile capacity of the reinforcing screws or threaded rods where  $\ell_{ef}$  is the smaller value of the penetration depth below or above the potential crack [N]

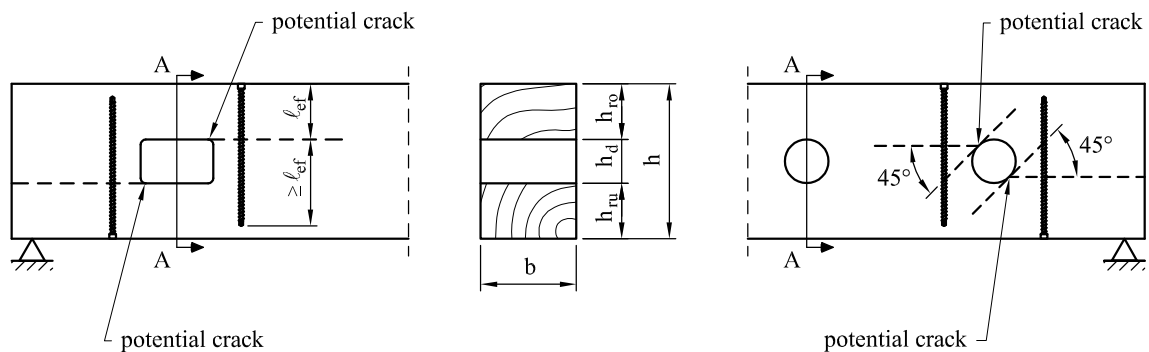

## **Annex E**

### **Thermal insulation on top of rafters**

Unifix SWG screws with an outer thread diameter  $6 \text{ mm} \leq d \leq 12 \text{ mm}$  may be used for the fixing of heat insulation on top of rafters.

The thickness of the insulation shall not exceed 400 mm. The rafter insulation must be placed on top of solid timber or glued laminated timber rafters or cross-laminated timber members and be fixed by battens arranged parallel to the rafters or by wood-based panels on top of the insulation layer. The insulation of vertical facades is also covered by the rules given here.

Screws must be screwed in the rafter through the battens or panels and the insulation without pre-drilling in one sequence.

The angle  $\alpha$  between the screw axis and the grain direction of the rafter should be between  $30^\circ$  and  $90^\circ$ .

The rafter consists of solid timber (softwood) according to EN 338, glued laminated timber according to EN 14081, cross-laminated timber, or laminated veneer lumber according to EN 14374 or to European Technical Assessment or similar glued members according to European Technical Assessment.

The battens must be from solid timber (softwood) according to EN 338. The minimum thickness  $t$  and the minimum width  $b$  of the solid timber battens is given as follows:

Screws $d \leq 8,0 \text{ mm}$ :	$b_{\min} = 50 \text{ mm}$	$t_{\min} = 30 \text{ mm}$
Screws $d = 10,0 \text{ mm}$ :	$b_{\min} = 60 \text{ mm}$	$t_{\min} = 40 \text{ mm}$
Screws $d = 12,0 \text{ mm}$ :	$b_{\min} = 80 \text{ mm}$	$t_{\min} = 100 \text{ mm}$

The insulation must comply with a European Technical Assessment.

Friction forces shall not be considered for the design of the characteristic axial capacity of the screws.

The anchorage of wind suction forces as well as the bending stresses of the battens or the boards, respectively, shall be considered in design. Additional screws perpendicular to the grain of the rafter (angle  $\alpha = 90^\circ$ ) may be arranged if necessary.

The maximum screw spacing is  $e_s = 1,75 \text{ m}$ .

### Thermal insulation on rafters with parallel inclined screws

#### Mechanical model

The system of rafter, heat insulation material on top of rafter and battens parallel to the rafter may be considered as a beam on elastic foundation. The batten represents the beam, and the heat insulation material on top of the rafter the elastic foundation. The minimum compression stress of the heat insulation material at 10 % deformation, measured according to EN 826<sup>1</sup>, shall be  $\sigma_{10\%} = 0,05 \text{ N/mm}^2$ . The batten is loaded perpendicular to the axis by point loads  $F_b$ . Further point loads  $F_s$  are from the shear load of the roof due to dead and snow load, which are transferred from the screw heads into the battens.

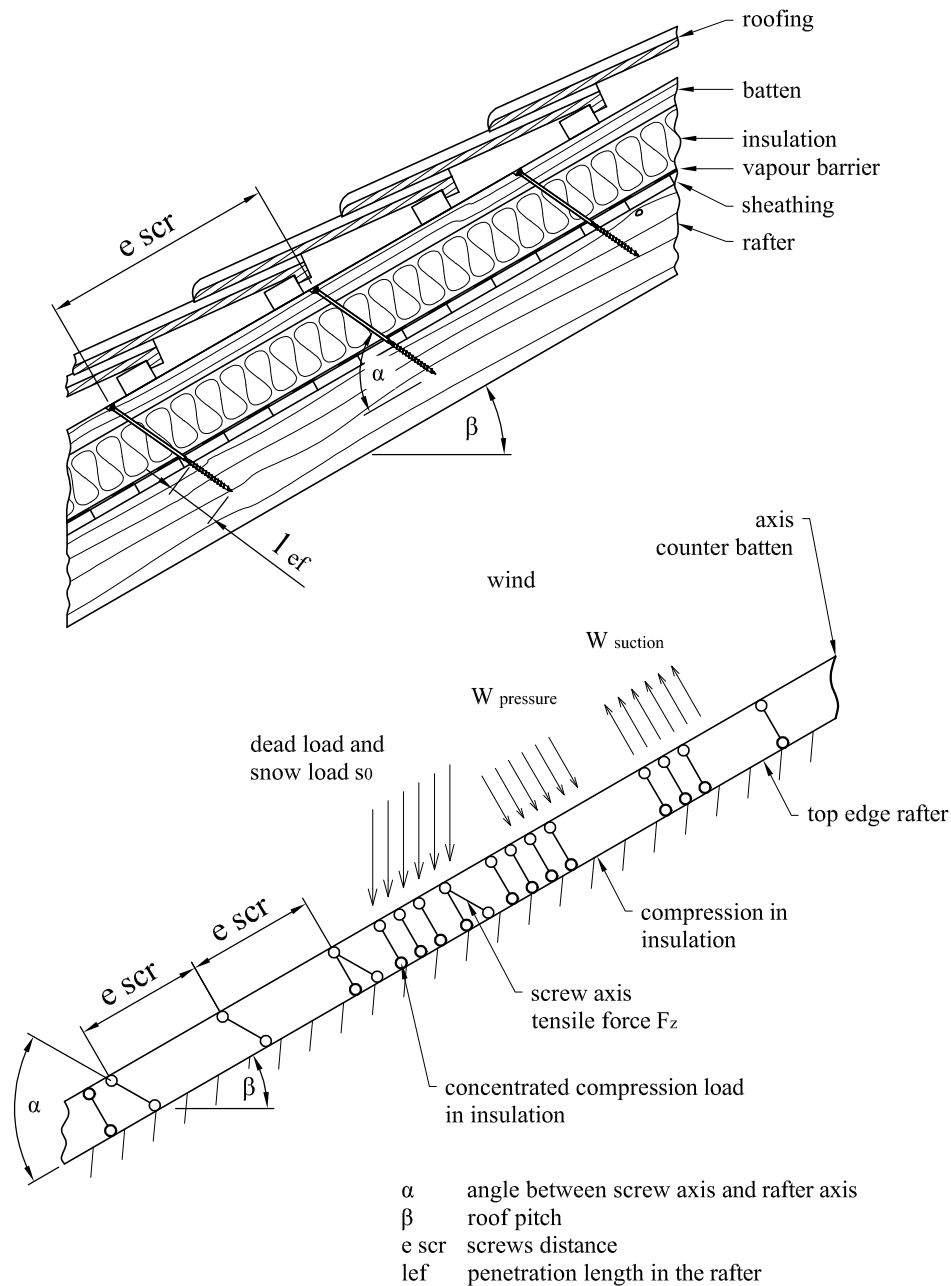

<sup>1</sup>EN 826:1996 Thermal insulating products for building applications - Determination of compression behaviour

### Thermal insulation on rafters with parallel inclined screws

#### Design of the battens

The bending stresses are calculated as:

$$M = \frac{(F_b + F_s) \cdot \ell_{\text{char}}}{4}$$

Where

$F_b$  point loads perpendicular to the battens [N]

$F_s$  point loads perpendicular to the battens, load application in the area of the screw heads [N]

$\ell_{\text{char}}$  characteristic length  $\ell_{\text{char}} = \sqrt[4]{\frac{4 \cdot EI}{w_{\text{ef}} \cdot K}}$  [mm]

$EI$  bending stiffness of the batten [ $\text{N}/\text{mm}^2 \cdot \text{mm}^4$ ]

$w_{\text{ef}}$  effective width of the thermal insulation material [mm]

$K$  coefficient of subgrade

The coefficient of subgrade  $K$  may be calculated from the modulus of elasticity  $E_{\text{HI}}$  and the thickness  $t_{\text{HI}}$  of the heat insulation material if the effective width  $w_{\text{ef}}$  of the heat insulation material under compression is known. Due to the load extension in the heat insulation material the effective width  $w_{\text{ef}}$  is greater than the width of the batten or rafter, respectively. For further calculations, the effective width  $w_{\text{ef}}$  of the heat insulation material may be determined according to:

$$w_{\text{ef}} = w + t_{\text{HI}}/2$$

Where

$w$  minimum width of the batten or rafter, respectively [mm]

$t_{\text{HI}}$  thickness of the heat insulation [mm]

$$K = \frac{E_{\text{HI}}}{t_{\text{HI}}}$$

The following condition shall be satisfied:

$$\frac{\sigma_{\text{m,d}}}{f_{\text{m,d}}} = \frac{M_{\text{d}}}{W \cdot f_{\text{m,d}}} \leq 1$$

For the calculation of the section modulus  $W$  of the net cross section has to be considered.

The shear stresses shall be calculated according to:

$$V = \frac{(F_b + F_s)}{2}$$

The following condition shall be satisfied:

$$\frac{\tau_{\text{d}}}{f_{\text{v,d}}} = \frac{1,5 \cdot V_{\text{d}}}{A \cdot f_{\text{v,d}}} \leq 1$$

#### Design of the heat insulation material

The compressive stresses in the thermal insulation material shall be calculated according to:

$$\sigma = \frac{1,5 \cdot F_b + F_s}{2 \cdot \ell_{\text{char}} \cdot w}$$

The design value of the compressive stress shall not be greater than 110 % of the compressive stress at 10 % deformation calculated according to EN 826.

## Thermal insulation on rafters with parallel inclined screws

### Design of the screws

Alternatively to the battens, wood-based panels with a minimum thickness of 20 mm from plywood according to EN 636, particle board according to EN 312, oriented strand board OSB/3 and OSB/4 according to EN 300 or European Technical Approval and solid wood panels according to EN 13353 or cross laminated timber may be used.

The insulation must have a minimum compressive stress of  $\sigma_{10\%} = 0,05 \text{ N/mm}^2$  at 10 % deformation according to EN 826.

The analysis of the fixing of the insulation and battens or boards, respectively, may be carried out using the static model showed on previous pages. The battens or boards, respectively, must have sufficient strength and stiffness. The maximum design value of the compressive stress between the battens or boards, respectively, and the insulation shall not exceed  $1,1 \cdot \sigma_{10\%}$ .

The screws are loaded predominantly axially. The axial tension force in the screw may be calculated from the shear loads of the roof  $R_s$ :

$$T_s = \frac{R_s}{\cos \alpha}$$

The design axial capacity of the "WBS EVO T" and "WBS EVO VAB" screws for rafter or facade insulation shall be calculated from:

$$F_{ax,\alpha,Rd} = \min \left\{ k_{ax} \cdot f_{ax,d} \cdot d \cdot \ell_{ef,r} \cdot k_1 \cdot k_2 \cdot \left( \frac{\rho_{k,r}}{350} \right)^{0,8} ; f_{head,d} \cdot d_h^2 \cdot \left( \frac{\rho_{k,b}}{350} \right)^{0,8} ; \frac{f_{tens,k}}{\gamma_{M2}} \right\}$$

The design axial capacity of the "WBS EVO VFT" or "WBS EVO VF-DUO" screws for rafter or facade insulation shall be calculated from:

$$F_{ax,\alpha,Rd} = \min \left\{ k_{ax} \cdot f_{ax,d} \cdot d \cdot \ell_{ef,r} \cdot k_1 \cdot k_2 \cdot \left( \frac{\rho_{k,r}}{350} \right)^{0,8} ; \max \left\{ f_{head,d} \cdot d_h^2 ; k_{ax} \cdot f_{ax,d} \cdot d \cdot \ell_{ef,b} \right\} \cdot \left( \frac{\rho_{k,b}}{350} \right)^{0,8} ; \frac{f_{tens,k}}{\gamma_{M2}} \right\}$$

Where

$F_{ax,\alpha,Rd}$  design axial capacity of the screw at an angle  $\alpha$  to the grain [N]

$k_{ax} = 1,0$  for  $45^\circ \leq \alpha \leq 90^\circ$

$= 0,3 + (0,7 \cdot \alpha/45^\circ)$  for  $0^\circ \leq \alpha < 45^\circ$

$f_{ax,d}$  design withdrawal parameter [N/mm<sup>2</sup>]

$d$  outer thread diameter [mm]

$d_h$  head diameter [mm]

$\ell_{ef,r}$  point side penetration length of the threaded part according to EN 1995-1-1 [mm]

$\ell_{ef,b}$  length of the threaded part in the batten [mm]

$\alpha$  angle between grain and screw axis ( $\alpha \geq 30^\circ$ )

$k_1 = \min \{1; 220/t_{HI}\}$

$k_2 = \min \{1; \sigma_{10\%}/0,12\}$

If equation  $k_1$  and  $k_2$  are considered, the deflection of the battens does not need to be considered.

$t_{HI}$  thickness of the heat insulation [mm]

$\sigma_{10\%}$  compressive stress of the heat insulation under 10 % deformation [N/mm<sup>2</sup>]

$\sigma_{10\%} \geq 0,05 \text{ N/mm}^2$

$\rho_{k,r}$  characteristic density of the rafter [kg/m<sup>3</sup>]

$\rho_{k,b}$  characteristic density of the batten [kg/m<sup>3</sup>]

$f_{head,d}$  design head pull-through parameter [N/mm<sup>2</sup>]

$f_{tens,k}$  characteristic tensile capacity [N]

$\gamma_{M2}$  partial safety factor according to EN 1993-1-1 or according to national annex

### Thermal insulation on rafters with parallel inclined screws

#### Fixing of battens with parallel screws perpendicular to the roof plane

Alternatively to the battens, wood-based panels with a minimum thickness of 20 mm from plywood according to EN 636, particle board according to EN 312, oriented strand board OSB/3 and OSB/4 according to EN 300 or European Technical Assessment and solid wood panels according to EN 13353 or cross laminated timber may be used.

The insulation must have a minimum compressive stress of  $\sigma_{10\%} = 0,05 \text{ N/mm}^2$  at 10 % deformation according to EN 826.

The battens or wood-based panels, respectively, must have sufficient strength and stiffness. The maximum design value of the compressive stress between the battens or boards, respectively, and the insulation shall not exceed  $1,1 \cdot \sigma_{10\%}$ .

The characteristic load-carrying capacity of the screws loaded in shear may be calculated from:

$$F_{v,Rk} = \min \left\{ \begin{array}{l} f_{h,b,k} \cdot d \cdot t_b \\ f_{h,r,k} \cdot d \cdot t_r \\ \frac{f_{h,b,k} \cdot d \cdot \beta}{1 + \beta} \cdot \left( \sqrt{4t_{il}^2 + \left(2 + \frac{1}{\beta}\right)t_b^2 + (2 + \beta)t_r^2 + 4t_{il}(t_b + t_r) + 2t_b t_r - 2t_{il} - t_b - t_r} \right) + \frac{F_{ax,Rk}}{4} \\ 1,05 \cdot \frac{f_{h,b,k} \cdot d \cdot \beta}{\frac{1}{2} + \beta} \cdot \left( \sqrt{t_{il}^2 + t_{il}t_b + \frac{t_b^2}{2}\left(1 + \frac{1}{\beta}\right) + \frac{M_{y,k}}{f_{h,b,k} \cdot d} \left(1 + \frac{2}{\beta}\right) - t_{il} - \frac{t_b}{2}} \right) + \frac{F_{ax,Rk}}{4} \\ 1,05 \cdot \frac{f_{h,b,k} \cdot d \cdot \beta}{\frac{1}{2} + \beta} \cdot \left( \sqrt{t_{il}^2 + t_{il}t_r + \frac{t_r^2}{2}\left(1 + \frac{1}{\beta}\right) + \frac{M_{y,k}}{f_{h,b,k} \cdot d} \left(2 + \frac{1}{\beta}\right) - t_{il} - \frac{t_r}{2}} \right) + \frac{F_{ax,Rk}}{4} \\ 1,15 \cdot \frac{f_{h,b,k} \cdot d \cdot \beta}{1 + \beta} \cdot \left( \sqrt{\beta^2 t_{il}^2 + 4\beta(\beta + 1) \cdot \frac{M_{y,k}}{f_{h,b,k} \cdot d} - \beta t_{il}} \right) + \frac{F_{ax,Rk}}{4} \end{array} \right.$$

Where

$f_{h,b,k}$  characteristic batten embedding strength [N/mm<sup>2</sup>]

$f_{h,r,k}$  characteristic rafter embedding strength [N/mm<sup>2</sup>]

$\beta$   $f_{h,r,k}/f_{h,b,k}$

$d$  outer thread diameter [mm]

$t_b$  batten thickness [mm]

$t_r$  lower value of rafter thickness or screw penetration length [mm]

$t_{il}$  interlayer thickness [mm]

$M_{y,k}$  characteristic fastener yield moment [Nmm]

$F_{ax,Rk}$  characteristic axial capacity of the screw [N]

## Thermal insulation on rafters with alternatively inclined screws

### Mechanical model

Depending on the screw spacing and the arrangement of tensile and compressive screws with different inclinations the battens are loaded by significant bending moments. The bending moments are derived based on the following assumptions:

- The tensile and compressive loads in the screws are determined based on equilibrium conditions from the actions parallel and perpendicular to the roof plane. These actions are constant line loads  $q_{\perp}$  and  $q_{\parallel}$ .
- The screws act as hinged columns supported 10 mm within the batten or rafter, respectively. The effective column length consequently equals the length of the screw between batten and rafter plus 20 mm.
- The batten is considered as a continuous beam with a constant span  $\ell = A + B$ . The compressive screws constitute the supports of the continuous beam while the tensile screws transfer concentrated loads perpendicular to the batten axis.

The screws are predominantly loaded in withdrawal or compression, respectively. The screw's normal forces are determined based on the loads parallel and perpendicular to the roof plane:

$$\text{compressive screw: } F_{c,Ed} = (A + B) \cdot \left( -\frac{q_{\parallel}}{\cos\alpha_1 + \sin\alpha_1 / \tan\alpha_2} - \frac{q_{\perp} \cdot \sin(90^\circ - \alpha_2)}{\sin(\alpha_1 + \alpha_2)} \right)$$

$$\text{tensile screw: } F_{t,Ed} = (A + B) \cdot \left( \frac{q_{\parallel}}{\cos\alpha_2 + \sin\alpha_2 / \tan\alpha_1} - \frac{q_{\perp} \cdot \sin(90^\circ - \alpha_1)}{\sin(\alpha_1 + \alpha_2)} \right)$$

The bending moments in the batten follow from the constant line load  $q_{\perp}$  and the load components perpendicular to the batten from the tensile screws. The span of the continuous beam is  $(A + B)$ . The load component perpendicular to the batten from the tensile screw is:

$$F_{ZS,Ed} = (A + B) \cdot \left( \frac{q_{\parallel}}{1 / \tan\alpha_1 + 1 / \tan\alpha_2} - \frac{q_{\perp} \cdot \sin(90^\circ - \alpha_1) \cdot \sin\alpha_2}{\sin(\alpha_1 + \alpha_2)} \right)$$

Where

$q_{\parallel}$  constant line load parallel to batten

$q_{\perp}$  constant line load perpendicular to batten

$\alpha_1$  angle between compressive screw axis and grain direction

$\alpha_2$  angle between tensile screw axis and grain direction

A positive value for  $F_{ZS}$  means a load towards the rafter, a negative value a load away from the rafter.

**Thermal insulation on rafters with alternatively inclined screws**

**Mechanical model**

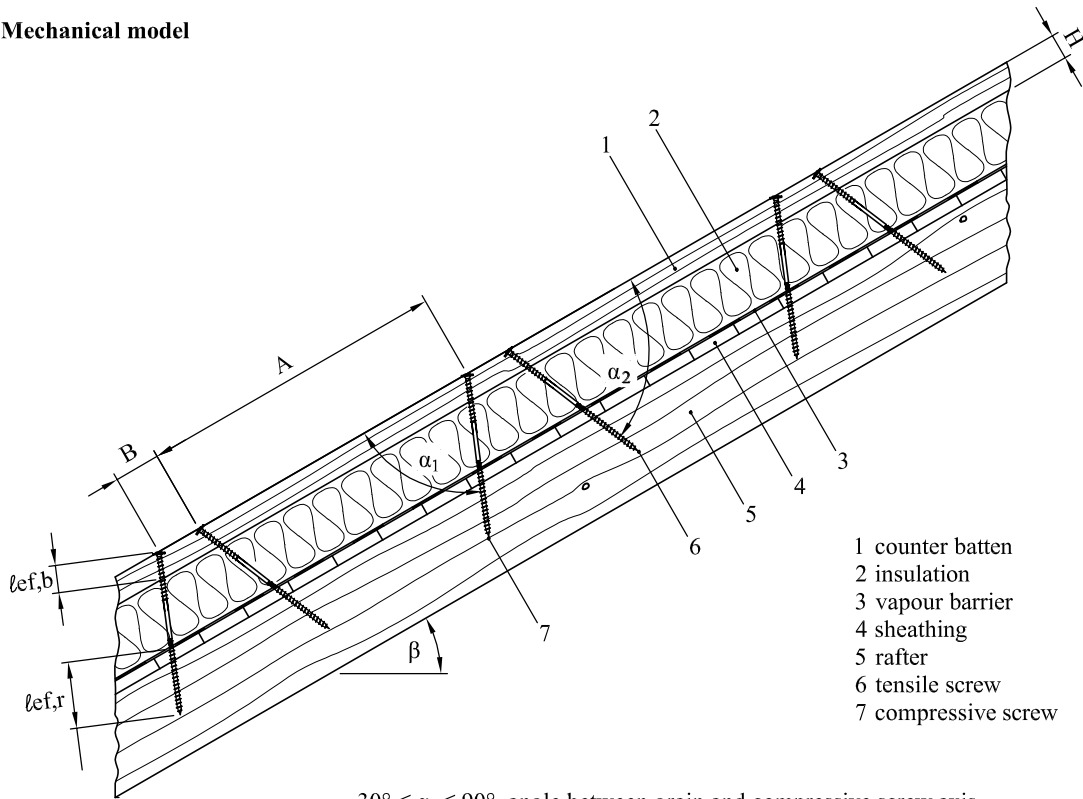

$30^\circ \leq \alpha_1 \leq 90^\circ$ , angle between grain and compressive screw axis  
 $30^\circ \leq \alpha_2 \leq 90^\circ$ , angle between grain and tensile screw axis

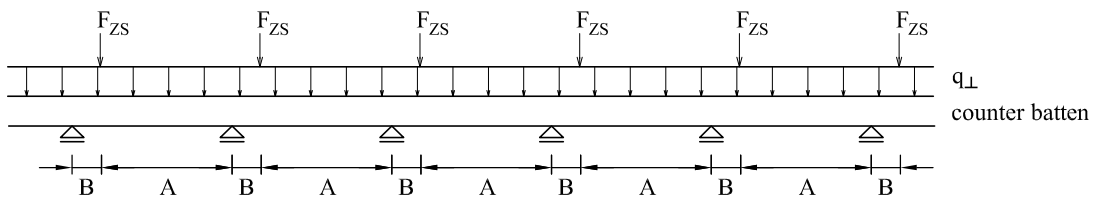

$$\text{compressive screw: } F_{c,Ed} = (A + B) \cdot \left( -\frac{q_{\parallel}}{\cos\alpha_1 + \sin\alpha_1 / \tan\alpha_2} - \frac{q_{\perp} \cdot \sin(90^\circ - \alpha_2)}{\sin(\alpha_1 + \alpha_2)} \right)$$

$$\text{tensile screw: } F_{t,Ed} = (A + B) \cdot \left( \frac{q_{\parallel}}{\cos\alpha_2 + \sin\alpha_2 / \tan\alpha_1} - \frac{q_{\perp} \cdot \sin(90^\circ - \alpha_1)}{\sin(\alpha_1 + \alpha_2)} \right)$$

$$\text{concentrated load: } F_{ZS,Ed} = (A + B) \cdot \left( \frac{q_{\parallel}}{1 / \tan\alpha_1 + 1 / \tan\alpha_2} - \frac{q_{\perp} \cdot \sin(90^\circ - \alpha_1) \cdot \sin\alpha_2}{\sin(\alpha_1 + \alpha_2)} \right)$$

Where

$q_{\parallel}$  constant line load parallel to batten

$q_{\perp}$  constant line load perpendicular to batten

$\alpha_1$  angle between compressive screw axis and grain direction

$\alpha_2$  angle between tensile screw axis and grain direction

A positive value for  $F_{ZS}$  means a load towards the rafter, a negative value a load away from the rafter.

### Thermal insulation on rafters with alternatively inclined screws

#### Design of the screws

The analysis of the fixing of the insulation and battens may be carried out using the static model showed on previous page. The battens must have sufficient strength and stiffness.

The design axial tensile capacity of the "WBS EVO VFT" or "WBS EVO VF-DUO" screws for rafter or facade insulation shall be calculated from:

$$F_{ax,a,Rd} = \min \left\{ \max \left\{ \begin{matrix} f_{head,d} \cdot d_h^2 \\ k_{ax} \cdot f_{ax,d} \cdot d \cdot \ell_{ef,b} \end{matrix} \right\} \cdot \left( \frac{\rho_{k,b}}{350} \right)^{0,8} ; k_{ax} \cdot f_{ax,d} \cdot d \cdot \ell_{ef,r} \cdot \left( \frac{\rho_{k,r}}{350} \right)^{0,8} ; \frac{f_{tens,k}}{\gamma_{M2}} \right\}$$

The design axial compressive capacity of the "WBS EVO VFT" or "WBS EVO VF-DUO" screws for rafter or facade insulation shall be calculated from:

$$F_{ax,a,Rd} = \min \left\{ k_{ax} \cdot f_{ax,d} \cdot d \cdot \ell_{ef,b} \cdot \left( \frac{\rho_{k,b}}{350} \right)^{0,8} ; k_{ax} \cdot f_{ax,d} \cdot d \cdot \ell_{ef,r} \cdot \left( \frac{\rho_{k,r}}{350} \right)^{0,8} ; \frac{F_{ki,Rk}}{\gamma_{M1}} \right\}$$

Where

- $F_{ax,a,Rd}$  design axial capacity of the screw at an angle  $\alpha$  to the grain [N]
- $f_{head,d}$  design head pull-through parameter [N/mm<sup>2</sup>]
- $d_h$  head diameter [mm]
- $k_{ax}$  = 1,0 for  $45^\circ \leq \alpha \leq 90^\circ$   
= 0,3 + (0,7 ·  $\alpha$ /45°) for  $0^\circ \leq \alpha < 45^\circ$
- $f_{ax,d}$  design withdrawal parameter [N/mm<sup>2</sup>]
- $d$  outer thread diameter [mm]
- $\ell_{ef,b}$  length of the threaded part in the batten [mm]
- $\ell_{ef,r}$  point side penetration length of the threaded part according to EN 1995-1-1 [mm]
- $\alpha$  angle between grain and screw axis ( $\alpha \geq 30^\circ$ )
- $\rho_{k,b}$  characteristic density of the batten [kg/m<sup>3</sup>]
- $\rho_{k,r}$  characteristic density of the rafter [kg/m<sup>3</sup>]
- $f_{tens,k}$  characteristic tensile capacity [N]
- $F_{ki,Rk}$  characteristic compressive capacity depending on free screw length between counter batten and rafter [N]
- $\gamma_{M1}, \gamma_{M2}$  partial safety factor according to EN 1993-1-1 or according to national annex

Free screw length [mm]	"WBS EVO VFT" screws				WBS EVO VF-DUO
	Ø6,5	Ø8,0	Ø10,0	Ø11,3	Ø8,0
	$F_{ki,Rk}$ [kN]	$F_{ki,Rk}$ [kN]	$F_{ki,Rk}$ [kN]	$F_{ki,Rk}$ [kN]	$F_{ki,Rk}$ [kN]
≤ 120	2,32	4,28	6,76	18,80	5,97
140	1,75	3,27	5,21	14,90	4,59
160	1,38	2,57	4,12	12,00	3,62
180	1,10	2,08	3,33	9,85	2,93
200	0,91	1,71	2,75	8,20	2,42
220	0,76	1,43	2,31	6,93	2,03
240	0,64	1,21	1,96	5,92	1,72
260	0,55	1,04	1,69	5,12	1,48
280	0,48	0,91	1,47	4,48	1,29
300	0,42	0,79	1,29	3,94	1,13
320	0,37	0,70	1,14	3,49	1,00
340	0,33	0,62	1,01	3,12	0,89
360	0,29	0,56	0,91	2,80	0,80
380	0,26	0,50	0,82	2,52	0,72
400	0,24	0,46	0,74	2,29	0,65
420	0,22	0,42	0,68	2,09	0,59