



ETA-Danmark A/S
Göteborg Plads 1
DK-2150 Nordhavn
Tel. +45 72 24 59 00
Internet www.etadanmark.dk

Authorised and notified according
to Article 29 of the Regulation (EU)
No 305/2011 of the European
Parliament and of the Council of 9
March 2011

MEMBER OF EOTA



European Technical Assessment ETA-13/0757 of 2025/12/03

I General Part

Technical Assessment Body issuing the ETA and designated according to Article 29 of the Regulation (EU) No 305/2011: ETA-Danmark A/S

Trade name of the
construction product:

BB Joist Bearings

Product family to which the
above construction product
belongs:

Three-dimensional nailing plate (concealed beam
hangers)

Manufacturer:

BB Stanz- und Umformtechnik GmbH
Nordhäuser Str. 44
D-06536 Berga
Tel. +49 34651 2988 0
Fax +49 34651 2988 20
Internet www.bb-berga.de

Manufacturing plant:

BB Stanz- und Umformtechnik GmbH
Nordhäuser Str. 44
D-06536 Berga

This European Technical
Assessment contains:

14 pages including 3 annexes which form an integral
part of the document

This European Technical
Assessment is issued in
accordance with Regulation
(EU) No 305/2011, on the
basis of:

EAD 130186-00-0603, Three Dimensional Nailing
Plates

This version replaces:

The ETA with the same number issued on 2019/04/29

Translations of this European Technical Assessment in other languages shall fully correspond to the original issued document and should be identified as such.

Communication of this European Technical Assessment, including transmission by electronic means, shall be in full (excepted the confidential Annex(es) referred to above). However, partial reproduction may be made, with the written consent of the issuing Technical Assessment Body. Any partial reproduction has to be identified as such

II SPECIFIC PART OF THE EUROPEAN TECHNICAL ASSESSMENT

1 Technical description of the product

Technical description of the product

BB joist bearings are one-piece, face-fixed joist bearings to be used in timber to timber or timber to concrete or steel connections.

The joist bearings are made from aluminium alloy EN AW-6005A or EN AW-6060 according to EN 573-3:2007 with minimum yield strength $R_{eH} = 260 \text{ N/mm}^2$. Dimensions, hole positions, aluminium alloy and typical installations are shown in Annexes A and C.

2 Specification of the intended use in accordance with the applicable European Assessment Document (hereinafter EAD)

The joist bearings are intended for use in making end-grain to side-grain connections in load bearing timber structures, as a connection between a wood based joist and a solid timber or wood based header as well as connections between a timber joist and a concrete structure or a steel member, where requirements for mechanical resistance and stability and safety in use in the sense of the Basic Works Requirements 1 and 4 of Regulation (EU) 305/2011 shall be fulfilled.

The joist bearings can be installed as connections between wood based members such as:

- Structural solid softwood timber according to EN 338 / EN 14081,
- Glulam according to EN 1194 / EN 14080,
- LVL according to EN 14374,
- Parallam PSL,
- Intrallam LSL,
- Duo- and Triobalken,
- Cross laminated timber.

However, the calculation methods are only allowed for a characteristic wood density of up to 460 kg/m^3 . Even though the wood based material may have a larger density, this must not be used in the formulas for the load-carrying capacities of the fasteners.

Annex B states the formulas for the characteristic load-carrying capacities of the connections with joist bearings. The design of the connections shall be in accordance with Eurocode 5 or a similar national Timber Code.

It is assumed that the forces acting on the joist bearing connection are F_{up} or F_{down} or $F_{\text{horizontal}}$ perpendicular to the header axis. The forces F_{up} and F_{down} shall act in the symmetry plane of the joist bearing, the force $F_{\text{horizontal}}$ perpendicular to the symmetry plane. It is assumed that the forces are acting with an eccentricity e with regard to the side grain surface of the header.

It is assumed that the header beam is prevented from rotating. If the header beam only has installed a joist bearing on one side the eccentricity moment $M_v = F_d \cdot (B_H / 2 + e)$ shall be considered. The same applies when the header has joist bearing connections on both sides, but with vertical forces which differ more than 20%.

The joist bearings are intended for use for connections subject to static or quasi static loading.

The aluminium bearings are for use in timber structures subject to the dry, internal conditions defined by the service classes 1 and 2 of EN 1995-1-1:2004, (Eurocode 5).

The scope of the brackets regarding resistance to corrosion shall be defined according to national provisions that apply at the installation site considering environmental conditions.

The provisions made in this European Technical Assessment are based on an assumed intended working life of the joist bearings of 50 years.

The indications given on the working life cannot be interpreted as a guarantee given by the producer or Assessment Body, but are to be regarded only as a means for choosing the right products in relation to the expected economically reasonable working life of the works.

3 Performance of the product and references to the methods used for its assessment

Characteristic	Assessment of characteristic
3.1 Mechanical resistance and stability*) (BWR1)	
Joint Strength - Characteristic load-carrying capacity	See Annex B
Joint Stiffness	No performance assessed
Joint ductility	No performance assessed
Resistance to seismic actions	No performance assessed
Resistance to corrosion and deterioration	See section 3.5
3.2 Safety in case of fire (BWR2)	
Reaction to fire	The joist bearings are made from aluminium classified as Euroclass A1 in accordance with EN 13501-1 and Commission Delegated Regulation 2016/364
Resistance to fire	No performance assessed

*) See additional information in section 3.3 – 3.6.

3.3 Methods of verification

Safety principles and partial factors

The characteristic load-carrying capacities are based on the characteristic values of the connections with metal fasteners, the steel plates and the timber post.

In the case of timber failure or failure of the metal fasteners, the design values shall be calculated according to EN 1995-1-1 by dividing the characteristic values of the load-carrying capacities by different partial factors for the strength properties, and in addition multiplied with the coefficient k_{mod} .

In the case of steel failure, the design value shall be calculated according to EN 1993-1-1 by reducing the characteristic values of the load-carrying capacity with different partial factors.

The design value of the load-carrying capacity is the smaller value of all load-carrying capacities:

$$F_{Rd} = \min \left\{ \frac{k_{mod} \cdot F_{Rk,H}}{\gamma_{M,H}}, \frac{F_{Rk,S}}{\gamma_{M_i,S}} \right\}$$

Therefore, for timber failure or failure of the metal fasteners the load duration class and the service class are included. The different partial factors γ_M for steel or timber failure, respectively, are also correctly taken into account.

3.4 Mechanical resistance and stability

See annex B for characteristic load-carrying capacities of the joist bearings.

The characteristic capacities of the brackets are determined by calculation assisted by testing as described in EAD 130186-00-0603 clause 2.2.1. They should be used for designs in accordance with Eurocode 5 or a similar national Timber Code.

The design models allow the use of fasteners described in the table on page 9 in Annex A:

- *Threaded nails (ringed shank nails), bolts and dowels in accordance with EN 14592*
- *Metal anchors in accordance with an ETA*

In the formulas in Annex B the capacities for threaded nails calculated from the formulas of Eurocode 5 are used assuming a thick steel plate when calculating the lateral fastener load-carrying-capacity.

No performance has been assessed in relation to ductility of a joint under cyclic testing. The contribution to the performance of structures in seismic zones, therefore, has not been assessed.

No performance has been assessed in relation to the joint's stiffness properties - to be used for the analysis of the serviceability limit state.

3.5 Aspects related to the performance of the product

3.5.1 Corrosion protection in service class 1 and 2.

In accordance with EAD 130186-00-0603 the aluminium joist bearings are produced from aluminium alloys EN AW-6005A or EN AW-6060 according to EN 573-3:2007

3.6 General aspects related to the fitness for use of the product

Joist bearing connections

A joist bearing connection is assessed for its intended use provided:

Header – support conditions

- The header beam shall be restrained against rotation and be free from wane under the joist bearing.
- If the header carries joists only on one side the eccentricity moment from the joists $M_{ec} = R_{joist} (b_{header}/2 + 86\text{mm})$ shall be considered for the strength verification of the header.
- R_{joist} Reaction force from the joists
 b_{header} Width of header
- For a header with joists from both sides but with different reaction forces a similar consideration applies.

Wood to wood connections

- Joist bearings are fastened to wood-based headers by nails and to wood-based joists by dowels.
- There shall be nails and dowels in all holes.
- The characteristic capacity of the joist bearing connection is calculated according to the manufacturer's technical documentation, dated 2013-02-11.
- The joist bearing connection is designed in accordance with Eurocode 5 or an appropriate national code.
- The gap between the end of the joist and the surface, where contact stresses can occur during loading

shall be limited. This means that for joist bearings the gap between the surface of the flaps and the end of the joist shall be maximum 8 mm.

- The groove in the joist and the surface of the header shall have a plane surface against the whole joist bearing.
- The depth of the joist shall be so large that the top (bottom) of the joist is at least $a_{4,t}$ above (below) the upper (lower) dowel in the joist.
- Nails to be used shall have a diameter and head shape, which fits the holes of the joist bearings.

Wood to concrete or steel

The abovementioned rules for wood to wood connections are applicable also for the connection between the joist and the joist bearing.

- The joist bearing connection is designed in accordance with Eurocodes 2, 3, 5 or 9 or an appropriate national code.
- The joist bearing shall be in close contact with the concrete or steel over the whole face. There shall be no intermediate layers in between.
- The gap between the end of the joist and the surface, where contact stresses can occur during loading shall be limited. This means that the gap between the end grain surface of the joist and that of the concrete or steel shall be maximum 27 mm.
- The bolt or metal anchor shall have a diameter not less than the hole diameter minus 2 mm.
- The bolts or metal anchors shall be placed symmetrically about the vertical symmetry line. There shall always be bolts in the 2 upper holes.
- The upper bolts shall have washers according to EN ISO 7094.

4 Assessment and verification of constancy of performance (hereinafter AVCP) system applied, with reference to its legal base

4.1 AVCP system

According to the decision 97/638/EC of the European Commission¹, as amended, the system(s) of assessment and verification of constancy of performance (see Annex V to Regulation (EU) No 305/2011) is 2+.

5 Technical details necessary for the implementation of the AVCP system, as provided for in the applicable EAD

Technical details necessary for the implementation of the AVCP system are laid down in the control plan deposited at ETA-Danmark prior to CE marking.

Issued in Copenhagen on 2025-12-03 by



Thomas Bruun
Managing Director, ETA-Danmark

Annex A

Product details and definitions

BB Joist bearing

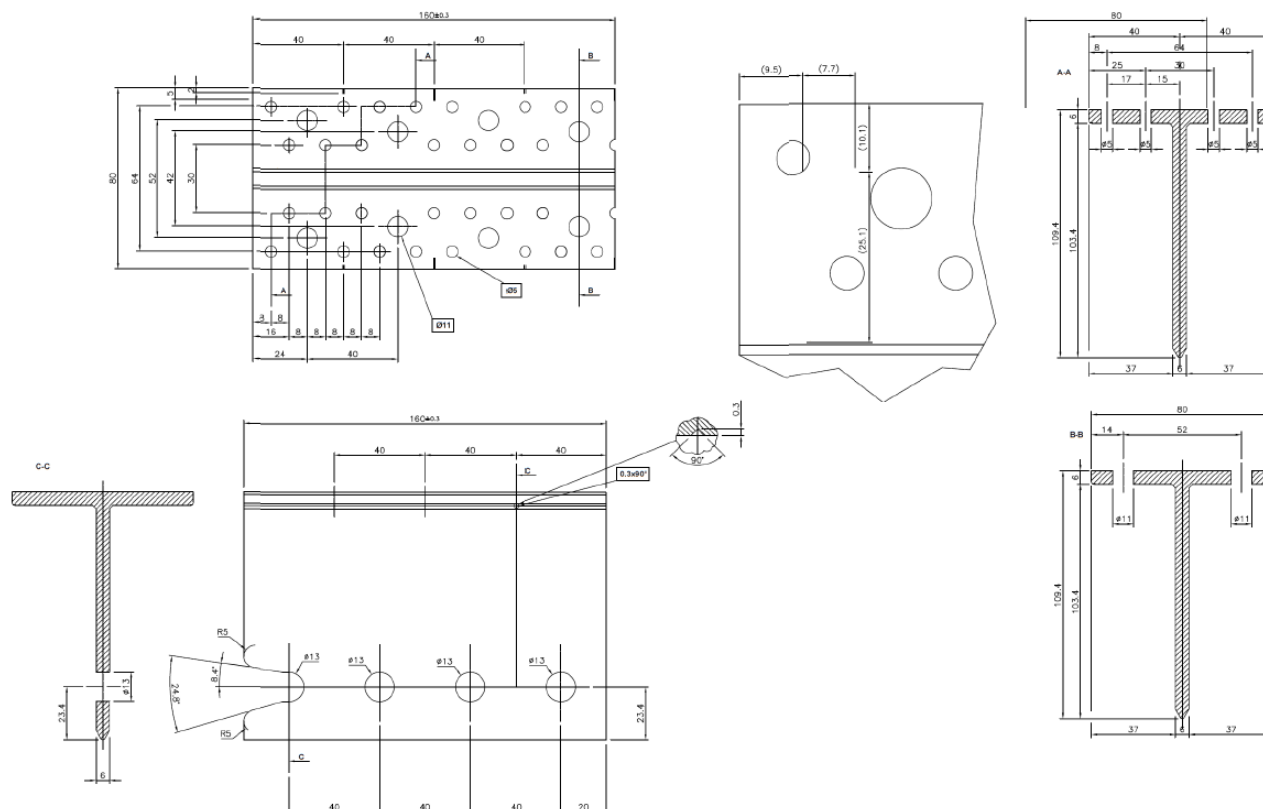
Face mount hanger with flanges with or without pre-punched holes for the joist connection. 6.0 mm thick aluminium alloy EN AW 6005A according to EN 573-3:2007 or EN AW-6060 according to EN 573-3:2007 with minimum yield strength $R_{eH} = 260 \text{ N/mm}^2$.



Drawing: BB Joist bearing 160 with pre-punched holes for the joist connection

Joist bearing	Size range [mm]	N° of nail holes		N° of dowel holes		N° of anchor/bolt holes	
		N°	d	N°	d	N°	d
80	80-119	14	5	2	13	4	11
120	120-159	22	5	3	13	6	11
160	160-199	30	5	4	13	8	11
200	200-239	38	5	5	13	10	11
240	240-279	46	5	6	13	12	11
280	280-319	54	5	7	13	14	11
320	320-359	62	5	8	13	16	11
360	360-399	70	5	9	13	18	11
400	400-439	78	5	10	13	20	11
440	440-479	86	5	11	13	22	11
480	480-499	94	5	12	13	24	11
500	500	94	5	12	13	24	11

For joist bearings without pre-punched holes, the distance of the centroid of the joist connection from the header surface must not exceed 86 mm. For this case, the provisions of Eurocode 5 regarding load-carrying capacity, minimum spacing, end or edge distances as well as minimum timber thickness have to be respected.

Since the joist bearings are cut from blanks with a length of 2200 mm, any intermediate size within the given size range is possible. For the load-carrying capacity the lowermost size within the size range is decisive.

Fastener types and sizes

NAIL diameter	Length	Nail type
4.0	50 - 100	Ringed shank nails according to EN 14592
<p>In the formulas in Annex B the capacities for threaded nails calculated from the formulas of Eurocode 5 are used assuming a thick steel plate when calculating the lateral nail load-carrying-capacity. The load bearing capacities of the joist bearings have been determined based on the use of connector nails 4,0 x L mm in accordance with the German national approval for the nails. The characteristic withdrawal capacity of the nails has to be determined by calculation in accordance with EN 1995-1-1, paragraph 8.3.2 (head pull-through is not relevant):</p> $F_{ax,Rk} = f_{i,k} \times d \times t_{pen}$ <p>Where:</p> <p>$f_{i,k}$ Characteristic value of the withdrawal parameter in N/mm²</p> <p>d Nail diameter in mm</p> <p>t_{pen} Penetration depth of the profiled shank in mm</p> <p>Based on tests by Versuchsanstalt für Stahl, Holz und Steine, University of Karlsruhe, the characteristic value of the withdrawal resistance for the threaded nails used can be calculated as:</p> $f_{i,k} = 50 \times 10^{-6} \times \rho_k^2$ <p>Where:</p> <p>ρ_k Characteristic density of the timber in kg/m³</p> <p>The shape of the nail directly under the head shall be in the form of a truncated cone with a diameter under the nail head which exceeds the hole diameter.</p>		

BOLTS, METAL ANCHORS or DOWELS diameter	Corresponding hole diameter in aluminium plate	Fastener type
10.0	Max. 1 mm larger than the bolt or dowel diameter	Bolts or dowels according to EN 14592, metal anchors according to manufacturer's specification
12.0		

Annex B
Characteristic values of load-carrying-capacities

The downward, upward or horizontally directed forces are assumed to act in the middle of the joist.

Only a full nailing pattern is specified, where there are nails in all the holes of the header connection. Also, dowels are placed in all the dowel holes in the joist.

For header connections with bolts or metal anchors, there must always be at least bolts or metal anchors in the upper two holes for loading DOWN or in the lower two holes for loading UP.

B.1 Joist bearings fastened with nails and dowels in pre-punched holes for loading DOWN or UP

$$F_{z,Rk} = \min \begin{cases} F_{z,J,Rk} \\ F_{z,H,Rk} \end{cases} \quad (\text{B.1-1})$$

With

$$F_{z,J,Rk} = \frac{F_{v,J,Rk} \cdot \sqrt{\frac{77}{84}}}{\sqrt{\left(\frac{1}{n_J}\right)^2 + \left(\frac{(86 - e) \cdot z_{J,max}}{I_{p,J}}\right)^2}} \quad (\text{B.1-2})$$

Where:

$F_{v,J,Rk}$ is the characteristic lateral load-carrying capacity of a dowel with two shear planes in the joist;

n_J is the total number of dowels in the joist for loading DOWN

($n_{J,DOWN} = n_J$)

is the total number of dowels in the joist minus 1 for loading UP

($n_{J,UP} = n_J - 1$);

e is the distance between the header surface and the assumed line of action of the force F_z , with $e \leq 86$ mm (see Figure B.1);

$z_{J,max}$ is the distance between the uppermost dowel and the centre of gravity of the joist connection (see Figure B.1)

$I_{p,J}$ is the polar moment of inertia of the joist connection.

For loading UP, the uppermost dowel shall not be considered.

and

$$F_{z,H,Rk} = \frac{1}{\sqrt{\left(\frac{1}{n_H \cdot F_{v,H,Rk}}\right)^2 + \left(\frac{e \cdot z_{H,max}}{I_{p,H,ax} \cdot F_{ax,H,Rk}}\right)^2}} \quad (\text{B.1-3})$$

Where:

$F_{v,H,Rk}$ is the characteristic lateral load-carrying capacity of a nail or screw in single shear in the header assuming a thick plate;

$F_{ax,H,Rk}$ is the characteristic axial load-carrying capacity of a nail or screw in the header;

n_H is the total number of nails or screws in the header;

e is the distance between the header surface and the assumed line of action of the force F_z , with $e \leq 86$ mm (see Figure B.1);

$z_{H,max}$ is the distance between the uppermost nail or screw in the header and the assumed centre of rotation of the joist;

$I_{p,H,ax}$ is the polar moment of inertia of the header connection where the centre of rotation of the joist may be assumed (see Figure B.1)
 10 mm above the lower end of the joist bearing for loading DOWN
 or
 10 mm below the upper end of the joist bearing for loading UP.

B.2 Joist bearings fastened with bolts or metal anchors and dowels in pre-punched holes for loading DOWN or UP

$$F_{z,Rk} = \min \begin{cases} F_{z,J,Rk} \\ F_{z,H,Rk} \end{cases} \quad (B.2-1)$$

With

$$F_{z,J,Rk} = \frac{F_{v,J,Rk} \cdot \sqrt{\frac{77}{84}}}{\sqrt{\left(\frac{1}{n_J}\right)^2 + \left(\frac{(86 - e) \cdot z_{J,max}}{I_{p,J}}\right)^2}} \quad (B.1-2)$$

Where:

$F_{v,J,Rk}$ is the characteristic lateral load-carrying capacity of a dowel with two shear planes in the joist;

n_J is the total number of dowels in the joist for loading DOWN

($n_{J,DOWN} = n_J$)

or

is the total number of dowels in the joist minus 1 for loading UP

($n_{J,UP} = n_J - 1$);

e is the distance between the header surface and the assumed line of action of the force F_z , with $e \leq 86$ mm (see Figure B.2);

$z_{J,max}$ is the distance between the uppermost dowel and the centre of gravity of the joist connection (see Figure B.2)

$I_{p,J}$ is the polar moment of inertia of the joist connection.

For loading UP, the uppermost dowel shall not be considered.

and

$$F_{z,H,Rk} = \frac{1}{\sqrt{\left(\frac{1}{n_H \cdot F_{v,H,Rk}}\right)^2 + \left(\frac{e \cdot z_{H,max}}{I_{p,H,ax} \cdot F_{ax,H,Rk}}\right)^2}} \quad (B.1-3)$$

Where:

$F_{v,H,Rk}$ is the characteristic value of the lateral load-carrying-capacity per bolt or metal anchor in the header connection;

$F_{ax,H,Rk}$ is the characteristic value of the axial load-carrying-capacity per bolt or metal anchor in the header;

n_H is the number of bolts or metal anchors in the header connection;

there must always be at least bolts or metal anchors in the upper two holes for loading DOWN or in the lower two holes for loading UP;

e is the distance between the header surface and the assumed line of action of the force F_z , with $e \leq 86$ mm (see Figure B.2);

$z_{H,max}$ is the distance between the uppermost bolt or metal anchor and the lower end of the joist bearing for loading DOWN

or

is the distance between the lowermost bolt or metal anchor and the upper end of the joist bearing for loading UP;

$I_{p,H,ax}$ is the polar moment of inertia of the header connection where the centre of rotation may be assumed at the lower end of the joist bearing for loading DOWN

or

at the upper end of the joist bearing for loading UP.

B.3 Joist bearings fastened with nails and dowels in non-pre-punched holes for loading DOWN or UP

See Chapter B.1

B.4 Joist bearings fastened with nails and dowels in pre-punched holes for loading HORIZONTAL

$$F_{y,Rk} = \min \begin{cases} F_{y,1,Rk} \\ F_{y,2,Rk} \end{cases} \quad (B.4-1)$$

With

$$F_{y,1,Rk} = \frac{H \cdot f_u}{10} \quad (B.4-2)$$

Where:

$F_{y,1,Rk}$ is the characteristic load-carrying bending-capacity of the aluminum plate in N

H is the total height of the joist bearing in mm;

f_u is the characteristic tensile strength of the aluminum in N/mm²

and

$$F_{y,2,Rk} = \frac{k_v \cdot f_{v,k} \cdot h_J \cdot \frac{b_J}{2}}{1,5} \quad (B.4-3)$$

Where:

$F_{y,2,Rk}$ is the characteristic load-carrying capacity of the notched joint

k_v is the reduction factor for notched beams (see EC5, 6.5.2);

h_J is the height of the joist (> H + 40mm);

b_J is the width of the joist (> 60mm);

$f_{v,k}$ is the characteristic shear strength of the joist material

B.5 Combined forces

If the forces F_y and F_z act at the same time, the following expression shall be satisfied:

$$\frac{F_{y,Ed}}{F_{y,Rd}} + \frac{F_{z,Ed}}{F_{z,Rd}} \leq 1,0 \quad (B.5-1)$$

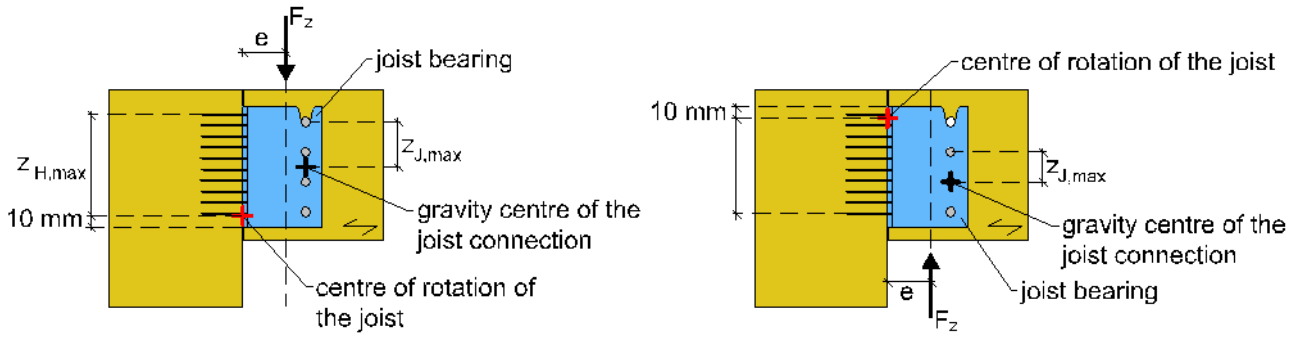

Figure B.1. Joist bearings fastened with nails and dowels for loading DOWN and UP

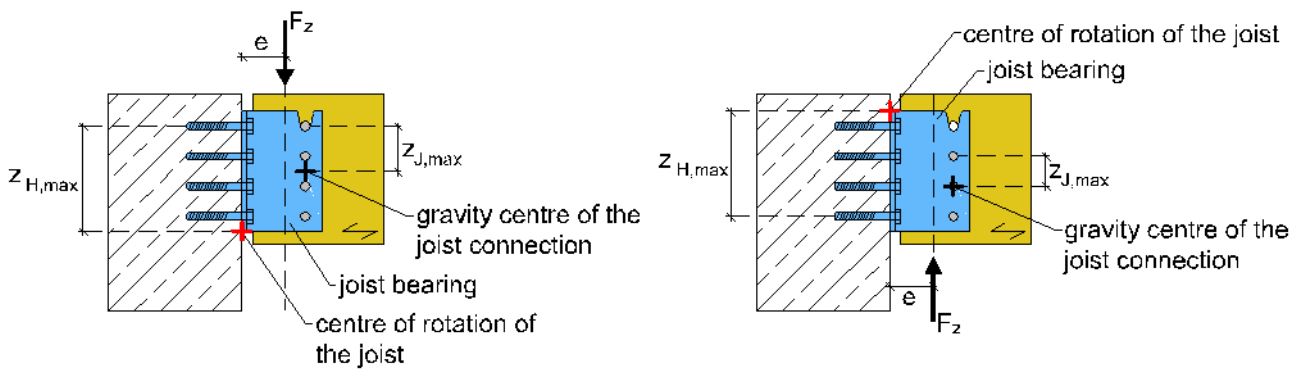

Figure B.2. Joist bearings fastened with bolts or metal anchors and dowels for loading DOWN and UP

Fig

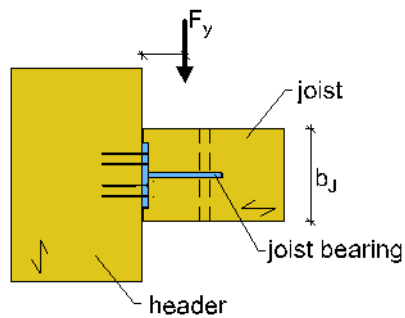

Figure B.3. Joist bearings fastened with nails and dowels for loading HORIZONTAL

Annex C Installation of joist bearings

